





















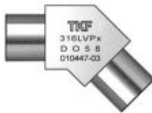

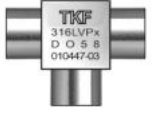











Weld & Metal Seal Fittings



























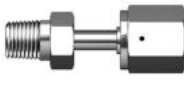







Weld Fittings / Metal Face Seal Fittings



INDEX

	Micro Reducer 15p		90° Elbow 17p		Socket Weld Reducing Long Gland 21p
	Micro Reducing 90° Elbow 15p		Reducing 90° Elbow 17p		Blind Gland 21p
	Micro 90° Elbow 15p		Tee 17p		Male Weld Gland 21p
	Micro Extended Leg 90° Elbow 15p		Reducing Tee 18p		Tube Adapter 21p
	Micro 45° Elbow 15p		Cross Tee 18p		Double Male Union 22p
	Micro Tee 16p		Reducer 18p		Double Male Reducing Union 22p
	Micro Reducing Tee 16p		Female Gland 20p		Bulkhead Union 22p
	Micro Cross 16p		Male Gland 20p		TBW Body 22p
	Micro Tribow 16p		ATW Female Long Gland 20p		TBW Bulkhead Connector 22p
	Micro Extended Run Leg Tee 16p		ATW Male Long Gland 20p		Coupling 22p
	Micro Extended Branch Leg Tee 17p		Socket Weld Short Gland 21p		Double Female Reducing Union 23p
	Micro Extended Leg 90° Elbow 17p		Socket Weld Long Gland 21p		Reducing Adapter 23p

· Dimensions are for reference only and are subject to change.

	Reducing Bushing 23p		Female Connector(PT) 26p		HMFS Male Nut 28p
	Male Elbow (PT) 23p		Female Connector(NPT) 26p		HMFS Long Gland 28p
	Male Elbow (NPT) 23p		Gasket Retainer Assembly 26p		HMFS TBW Body 28p
	Union Elbow 24p		Gasket 26p		HMFS ATW Body 29p
	Union Tee 24p		Blind Gasket 26p		HMFS Bulkhead Connector 29p
	Union Cross 24p		Female Nut 27p		Welded Male Connector(PT) 29p
	Tube Fitting Connector 24p		Male Nut 27p		Welded Male Connector(NPT) 29p
	Tube Fitting Bulkhead Connector 25p		Plug 27p		Welded Female Connector(PT) 29p
	Male Bulkhead Connector(NPT) 25p		Cap 27p		Welded Female Connector(NPT) 30p
	Male Connector(PT) 25p		Plug(Cable Type) 28p		Welded Lok Connector 30p
	Male Connector(NPT) 25p		Cap(Cable Type) 28p		Welded Female Union 30p
	Male Connector(ST) 25p		HMFS Female Nut 28p		

· Dimensions are for reference only and are subject to change.

HANDLING

Damage to the sealing beads may affect the fitting performance.

A protective cap is placed on all Metal Face Seal Fitting sealing beads to prevent nicks or scratches.

Keep this cap in place during storage and handling and only remove prior to assembly.

<Retainer Assembly>



Step 1.

When using a gasket retainer assembly, axially press the assembly onto the gland as shown. The retainer assembly will locate the gasket over the bead and hold it in place. Be careful not to scratch or nick the bead as this may affect fitting performance.

Proceed to Step 2.

<Non - Retainer Assembly>

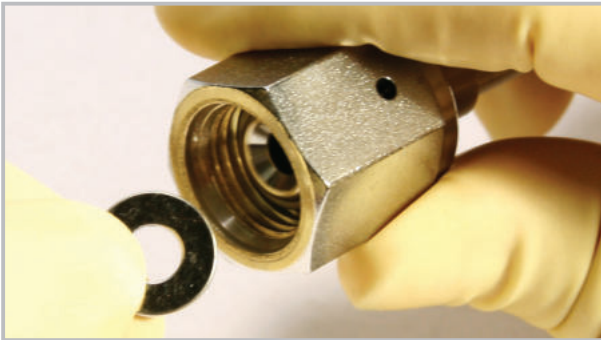

Step 1. Place gasket into female nut.

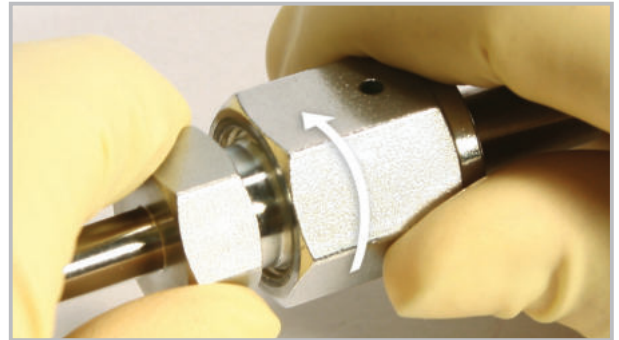

Step 2. Assemble components and snug to fingertight.

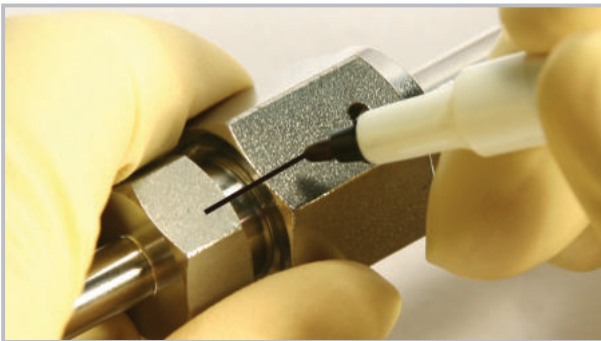

Step 3.

Scribe the hex flat of both the male and female

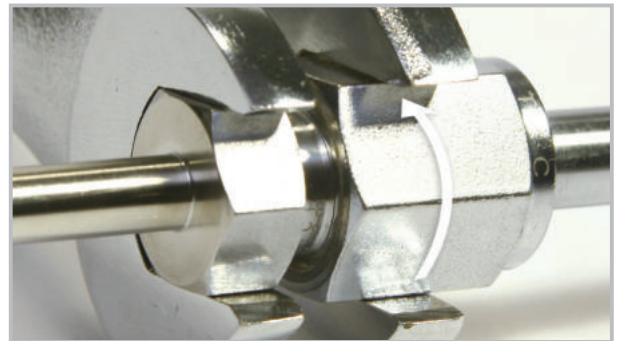

Step 4.

Holding the backup wrench stationary, tighten the female nut 1/8 turn past fingertight.

Warning : Extreme over tightening will damage toroid surface and cause potential leakage.

<Non - Retainer Assembly>



Protective Cap

Removing Face Seal in an assembled system requires minimal clearance. To disassemble a face seal connection, hold the male nut or body hex stationary with a backup wrench and loosen the female nut. After removing the components, be sure to protect the sealing beads with protective caps or gasket retainer assemblies.

TBW AND METAL FACE SEAL FITTINGS

Components are ordered by product code as listed in this catalogue

ORDERING INFORMATION



Material	Size	Sleeve Length	Inner Surface Level
S : 316L Stainless Steel	4 : 1/4"	6 : 6.35mm	BLANK : BA
D : 316L Stainless Steel Remelted	6 : 3/8"	10 : 10mm	P : EP
	8 : 1/2"	19 : 19.05mm	
	12 : 3/4"		
	16 : 1"		

Product			
E	Elbow	BLG	Blind Gland
T	Tee	MG	Male Weld Gland
CT	Cross	TA	Tube Adapter
TB	Tribow	BH	Bulkhead Union
R	Reducer	UC	Union Cross
FN	Female Nut	MC	Male Connector
MN	Male Nut	FC	Female Connector
CP	Cap	ME	Male Elbow
PG	Plug	UT	Union Tee
GT	Gasket	MU	Double Male Union
GB	Blind Gasket	FU	Double Female Union
GR	Gasket Retainer Assembly	UE	Union Elbow
SG	Female Gland	MCK	Tube Fitting Connector
ASG	Automatic Female Gland	BHCK	Tube Fitting Bulkhead Connector
SWSG	Socket Weld Short Gland	BHC	Male Bulkhead Connector
LG	Male Gland	CG	Coupling
ALG	Automatic Male Gland	RA	Reducing Adapter
SWLG	Socket Weld Long Gland	RB	Reducing Bushing
HLG	H-MFS Male Gland	HBY	H-MFS Tbw Body
HFN	H-MFS Female Nut	HABY	H-MFS Abw Body
HMN	H-MFS Male Nut	HBHY	H-MFS Bulkhead Connector

· Dimensions are for reference only and are subject to change.

WELD FITTINGS

MICRO WELD FITTINGS / FORGED WELD FITTINGS



FEATURES

- 316L Material
- Permanently Heat code marked; traceable to original mill certificate of test.
- Electropolished components permanently marked with designator on cube(P or PX)
- Critical surfaces are 100% visually inspected using magnification and lighting.

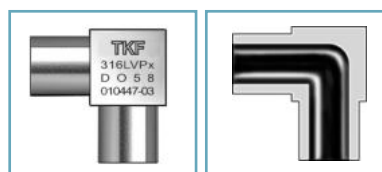

MATERIALS

Stainless Steel standards are in compliance with the below codes.

JIS G4303 / G3214 / G5121 / G3459 / G3463

ASTM A479 / A276 / A182 / A351 / A312 / A269

“Stainless Steel Remelted” is made of VAR(Vacuum Arc Remelting) material.

SPECIFICATIONS

Pressure Ratings will be governed by the tubing selected for a particular application. Working Pressures are calculated below for tubing using maximum allowable stress levels in accordance with ASME/ANSI B31.3, at ambient temperature.

- Dimensions are for reference only and are subject to change.
- Internal Surface Finishes: Standard finish Micro Fittings have an internal Surface Roughness of 3.0µm Ry / 10µin Ra.
- Electropolished Micro Fittings have an internal Surface Roughness of 0.7µm Ry / 5µin Ra.

Tube O.D.	Pressure Rating		Normal Wall Thickness
	psig	kgf/cm ²	
1/4in.	5100	358	1mm
3/8in.	3300	232	1mm
1/2in.	3500	246	1.24mm

Designator	Surface Finish(Ry)	Surface Finish(Ra)
	Maximum	Maximum
EP	0.7µm	5µinch
BA	3.0µm	10µinch

• Dimensions are for reference only and are subject to change.

MICRO WELD FITTINGS

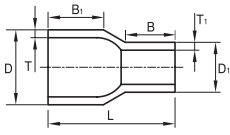

MICRO REDUCER

Size (OD)	Size (OD ₁)	Ordering Number	D	D ₁	T	T ₁	B	B ₁	L
3/8"	1/4"	□6 x 4R6	9.53	6.35	1.00	1.00	6.35	10.4	19.1
1/2"	1/4"	□8 x 4R6	12.70	6.35	1.24	1.00	6.35	10.4	19.1
1/2"	3/8"	□8 x 6R6	12.70	9.53	1.24	1.00	6.35	10.4	19.1
3/4"	1/4"	□12 x 4R6	19.05	6.35	1.65	1.00	6.35	10.4	19.1
3/4"	3/8"	□12 x 6R6	19.05	9.53	1.65	1.00	6.35	10.4	19.1
3/4"	1/2"	□12 x 8R6	19.05	12.70	1.65	1.24	6.35	10.4	19.1

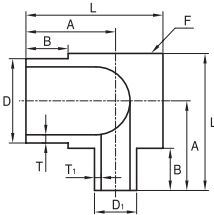

MICRO REDUCING 90° ELBOW

Size (OD)	Size (OD ₁)	Ordering Number	D	D ₁	T	T ₁	A	B	F Body Cube	L
3/8"	1/4"	□6 x 4E6	9.53	6.35	1.00	1.00	11.91	6.35	11.11	17.46
1/2"	1/4"	□8 x 4E6	12.70	6.35	1.24	1.00	13.50	6.35	14.29	20.64
1/2"	3/8"	□8 x 6E6	12.70	9.53	1.24	1.00	13.50	6.35	14.29	20.64
3/4"	1/4"	□12 x 4E6	19.05	6.35	1.65	1.00	16.68	6.35	20.65	27.00
3/4"	3/8"	□12 x 6E6	19.05	9.53	1.65	1.00	16.68	6.35	20.65	27.00
3/4"	1/2"	□12 x 8E6	19.05	12.70	1.65	1.24	16.68	6.35	20.65	27.00

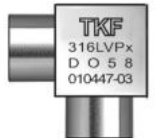
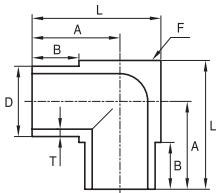

MICRO 90° ELBOW

Size (OD)	Ordering Number	D	T	A	B	F Body Cube	L
1/4"	□4E6	6.35	1.00	10.32	6.35	7.94	14.29
3/8"	□6E6	9.53	1.00	11.91	6.35	11.11	17.46
1/2"	□8E6	12.70	1.24	13.50	6.35	14.29	20.64
3/4"	□12E6	19.05	1.65	16.68	6.35	20.65	27.00

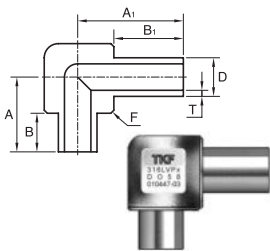

MICRO EXTENDED LEG 90° ELBOW

Size (OD)	Ordering Number	D	T	A	A ₁	B	B ₁	F Body Cube
1/4"	□4EX11	6.35	1.00	12.30	17.38	6.35	11.43	11.11

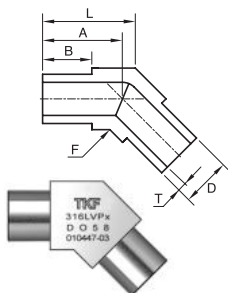

MICRO 45° ELBOW

Size (OD)	Ordering Number	D	T	A	B	F Body Cube	L
1/4"	□4HE6	6.35	1.00	10.32	6.35	7.94	11.96
3/8"	□6HE6	9.53	1.00	11.91	6.35	11.11	14.21
1/2"	□8HE6	12.70	1.24	13.50	6.35	14.29	16.46
3/4"	□12HE6	19.05	1.65	16.68	6.35	20.65	20.95

· Dimensions are for reference only and are subject to change.

WELD & METAL SEAL FITTINGS |

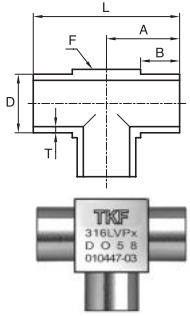

MICRO TEE

Size (OD)	Ordering Number	D	T	A	B	F Body Cube	L
1/4"	□4T6	6.35	1.00	10.32	6.35	7.94	20.64
3/8"	□6T6	9.53	1.00	11.91	6.35	11.11	23.81
1/2"	□8T6	12.70	1.24	13.50	6.35	14.29	26.99
3/4"	□12T6	19.05	1.65	16.68	6.35	20.65	33.35

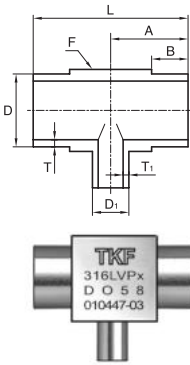

MICRO REDUCING TEE

Size (OD)	Size (OD ₁)	Ordering Number	D	D ₁	T	T ₁	A	B	F Body Cube	L
3/8"	1/4"	□6 x 4T6	9.53	6.35	1.00	1.00	11.91	6.35	11.11	23.81
1/2"	1/4"	□8 x 4T6	12.70	6.35	1.24	1.00	13.50	6.35	14.29	26.99
1/2"	3/8"	□8 x 6T6	12.70	9.53	1.24	1.00	13.50	6.35	14.29	26.99
3/4"	1/4"	□12 x 4T6	19.05	6.35	1.65	1.00	16.68	6.35	20.65	33.35
3/4"	3/8"	□12 x 6T6	19.05	9.53	1.65	1.00	16.68	6.35	20.65	33.35
3/4"	1/2"	□12 x 8T6	19.05	12.70	1.65	1.24	16.68	6.35	20.65	33.35

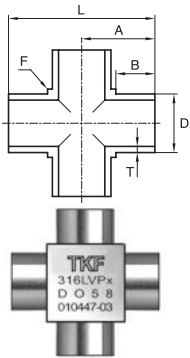

MICRO CROSS

Size (OD)	Ordering Number	D	T	A	B	F Body Cube	L
1/4"	□4CT6	6.35	1.00	10.32	6.35	7.94	20.64
3/8"	□6CT6	9.53	1.00	11.91	6.35	11.11	23.81
1/2"	□8CT6	12.70	1.24	13.50	6.35	14.29	26.99
3/4"	□12CT6	19.05	1.65	16.68	6.35	20.65	33.35

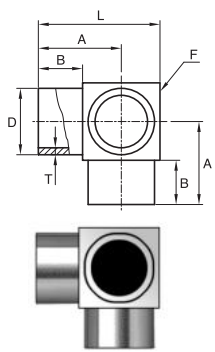

MICRO TRIBOW

Size (OD)	Ordering Number	D	T	A	B	F Body Cube	L
1/4"	□4TB6	6.35	1.00	10.32	6.35	7.94	14.29
3/8"	□6TB6	9.53	1.00	11.91	6.35	11.11	17.46
1/2"	□8TB6	12.70	1.24	13.50	6.35	14.29	20.64
3/4"	□12TB6	19.05	1.65	16.68	6.35	20.65	27.00

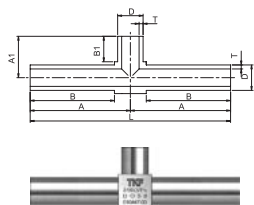

MICRO EXTENDED RUN TEE

Size (OD)	Ordering Number	D	T	B	A	L	B ₁	A ₁	F Body Cube
1/4"	□EXT50	6.35	1.00	21.05	25.00	50.00	6.35	10.32	7.94

· Dimensions are for reference only and are subject to change.

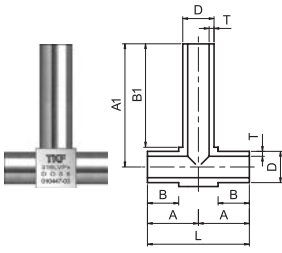

MICRO EXTENDED BRANCH LEG TEE

Size (OD)	Ordering Number	D	T	B	A	L	B ₁	A ₁	F Body Cube
1/4"	□EXT25	6.35	1.00	6.35	10.35	20.70	21.00	25.00	7.94

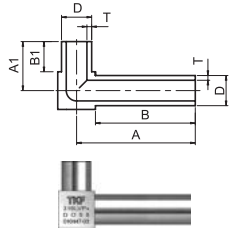

MICRO EXTENDED LEG 90° ELBOW

Size (OD)	Ordering Number	D	T	B	A	B ₁	A ₁	F Body Cube
1/4"	□EXE29	6.35	1.00	21.05	25.00	6.35	10.32	7.94

FORGED WELD FITTINGS

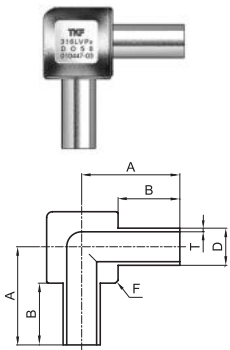

90° ELBOW

Size (OD)	Ordering Number	D	T	A	B	F Body Cube
1/4"	□4E19	6.35	1.00	25.0	19.05	11.1
3/8"	□6E19	9.53	1.00	25.0	19.05	11.1
1/2"	□8E19	12.70	1.24	29.0	19.05	17
1/4"	□4E10	6.35	1.00	15.9	10.00	11.1
3/8"	□6E10	9.53	1.00	15.9	10.00	11.1
1/2"	□8E10	12.70	1.24	19.9	10.00	17
3/4"	□12E10	19.05	1.65	22.4	10.00	25.0
3/4"	□12E22	19.05	1.65	33.5	22.5	25.0
1"	□16E23	25.4	1.65	38.5	23.3	30.0

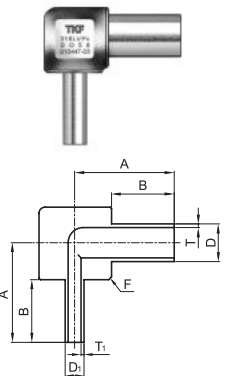

REDUCING 90° ELBOW

Size (OD)	Size (OD ₁)	Ordering Number	D	D ₁	T	T ₁	B	A	F Body Cube
3/8"	1/4"	□6 x 4E19	9.53	6.35	1.00	1.00	19.05	25	11.1
1/2"	1/4"	□8 x 4E19	12.70	6.35	1.24	1.00	19.05	29	17
1/2"	3/8"	□8 x 6E19	12.70	9.53	1.24	1.00	19.05	29	17
3/4"	1/4"	□12 x 4E22	19.05	6.35	1.65	1.00	22.5	34	25.0
1"	1/2"	□16 x 8E23	25.4	12.7	1.65	1.24	23.3	38.3	30.0

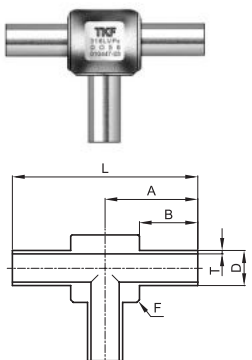

TEE

Size (OD)	Ordering Number	D	T	A	B	F Body Cube	L
1/4"	□4T19	6.35	1.00	25.0	19.05	11.1	50.0
3/8"	□6T19	9.53	1.00	25.0	19.05	11.1	50.0
1/2"	□8T19	12.70	1.24	29.0	19.05	17	58.0
1/4"	□4T10	6.35	1.00	15.9	10.00	11.1	31.8
3/8"	□6T10	9.53	1.00	15.9	10.00	11.1	31.8
1/2"	□8T10	12.70	1.24	19.9	10.00	17	39.8
3/4"	□12T10	19.05	1.65	22.4	10.00	25.0	44.8
3/4"	□12T22	19.05	1.65	33.5	22.5	25.0	67
1"	□16T23	25.4	1.65	38.3	23.3	30.0	76.6

· Dimensions are for reference only and are subject to change.

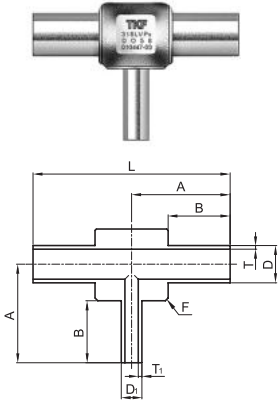

REDUCING TEE

Size (OD)	Size (OD ₁)	Ordering Number	D	D ₁	T	T ₁	A	B	F Body Cube	L
3/8"	1/4"	□ 6 x 4T19	9.53	6.35	1.00	1.00	25.0	19.05	11.1	50.0
1/2"	1/4"	□ 8 x 4T19	12.70	6.35	1.24	1.00	29.0	19.05	17	58.0
1/2"	3/8"	□ 8 x 6T19	12.70	9.53	1.24	1.00	29.0	19.05	17	58.0
3/4"	1/4"	□12 x 4T22	19.05	6.35	1.65	1.00	33.5	22.5	25	67
3/4"	3/8"	□12 x 6T22	19.05	9.53	1.65	1.00	33.5	22.5	25	67
3/4"	1/2"	□12 x 8T22	19.05	12.7	1.65	1.24	33.5	22.5	25	67
1"	1/4"	□16 x 4T23	25.4	6.35	1.65	1.00	38.3	23.3	30	76.6
1"	1/2"	□16 x 8T23	25.4	12.7	1.65	1.24	38.3	23.3	30	76.6
3/8"	1/4"	□ 6 x 4T10	9.53	6.35	1.00	1.00	15.9	10.00	11.1	31.8
1/2"	1/4"	□ 8 x 4T10	12.70	6.35	1.24	1.00	19.9	10.00	17	39.8
1/2"	3/8"	□ 8 x 6T10	12.70	9.53	1.24	1.00	19.9	10.00	17	39.8
3/4"	1/4"	□12 x 4T10	19.05	6.35	1.65	1.00	22.4	10.00	25.0	44.8
3/4"	3/8"	□12 x 6T10	19.05	9.53	1.65	1.00	22.4	10.00	25.0	44.8

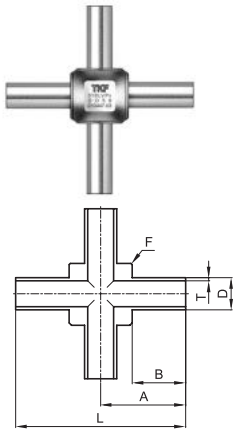

CROSS TEE

Size (OD)	Ordering Number	D	T	A	B	F Body Cube	L
1/4"	□4CT19	6.35	1.00	25.0	19.05	11.1	50.0
3/8"	□6CT19	9.53	1.00	25.0	19.05	11.1	50.0
1/2"	□8CT19	12.70	1.24	29.0	19.05	17	58.0
3/4"	□12CT19	19.05	1.65	31.5	19.05	25.0	63.0
1/4"	□4CT10	6.35	1.00	15.9	10.00	11.1	31.8
3/8"	□6CT10	9.53	1.00	15.9	10.00	11.1	31.8
1/2"	□8CT10	12.70	1.24	19.9	10.00	17	39.8
3/4"	□12CT10	19.05	1.65	22.4	10.00	25.0	44.8

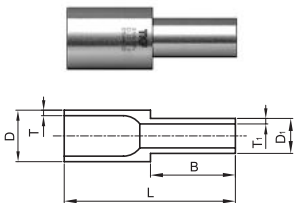

REDUCER

Size (OD)	Size (OD ₁)	Ordering Number	D	D ₁	T	T ₁	B	L
3/8"	1/4"	□ 6 x 4R19	9.53	6.35	1.00	1.00	19.05	38.1
1/2"	1/4"	□ 8 x 4R19	12.70	6.35	1.24	1.00	19.05	38.1
1/2"	3/8"	□ 8 x 6R19	12.70	9.53	1.24	1.00	19.05	38.1
3/4"	1/4"	□12 x 4R19	19.05	6.35	1.65	1.00	19.05	42.9
3/4"	3/8"	□12 x 6R19	19.05	9.53	1.65	1.00	19.05	42.9
3/4"	1/2"	□12 x 8R19	19.05	12.70	1.65	1.24	19.05	42.9
3/8"	1/4"	□ 6 x 4R10	9.53	6.35	1.00	1.00	10.00	20.0
1/2"	1/4"	□ 8 x 4R10	12.70	6.35	1.24	1.00	10.00	20.0
1/2"	3/8"	□ 8 x 6R10	12.70	9.53	1.24	1.00	10.00	20.0
3/4"	1/4"	□12 x 4R10	19.05	6.35	1.65	1.00	10.00	20.0
3/4"	3/8"	□12 x 6R10	19.05	9.53	1.65	1.00	10.00	20.0
3/4"	1/2"	□12 x 8R10	19.05	12.70	1.65	1.24	10.00	20.0

· Dimensions are for reference only and are subject to change.

METAL FACE SEAL FITTINGS

- GLANDS
- WELDED ASSEMBLIES
- GASKETS
- NUTS
- CAPS AND PLUGS
- HIGH-FLOW CONNECTIONS -“H” TYPE



High-Purity Nickel and Hastelloy C-22 glands for extremely corrosive applications. Non-Rotational Female Nut to prevent transmission of torque during make-up and therefore minimize twist of component which causes stress concentration.

MATERIALS

GLANDS, BODIES

Material	Ordering Number Designator	Applicable Specification
316L Stainless Steel	S	JIS G4303/G3214/G5121/G3459/G3463
316L Stainless Steel Remelted	D	ASTM A479/A276/A182/A351/A312/A269

SOME CONFIGURATION

GASKETS

Material	Ordering Number Designator	Applicable Specification
Nickel	UN	ASTM B162
316L Stainless Steel	US	ASTMA167

SPECIFICATIONS

- **Pressure Ratings** are based upon tests conducted using MFS assemblies. All ratings comply with calculations per ANSI Code for Pressure Piping B31.3.
- **Working Pressures** are rated at ambient temperature and are based on a 4 to 1 design factor. To determine pressure ratings in accordance with ANSI B31.1 multiply Working Pressures by 0.94.
- **Temperature Ratings**
 Fittings : Stainless Steel 316, 316L 1000°F(537°C)
 Gaskets : High-Purity Nickel 600°F(315°C)
 Stainless Steel 1000°F(537°C)
- **Dimensions** are for reference only and are subject to change
- **Plating** Female nuts are silver plated. Avoid chemical processes used for cleaning, electropolishing, and passivation that will remove plating. If the plating is damage or removed, thread galling may occur, damaging fitting components and preventing a proper seal.

- **Testing** products are rated to a Helium leak rate of 1×10^{-9} atm cc/sec.
- **Internal Surface Finishes:** components are available with controlled surface finishes and electropolished internal surfaces.
- **Cleaning and Packaging:** Ultra-High Purity cleaning and packaging in a Class 10 Clean Room environment validated per Federal Standard 209E, is standard for all electropolished components.

Designator	Surface Finish (Ry)	Surface Finish (Ra)
	Maximum	Maximum
EP	0.7µm	5 µinch
BA	3.0µm	10 µinch

TYPICAL FACE SEAL FITTINGS

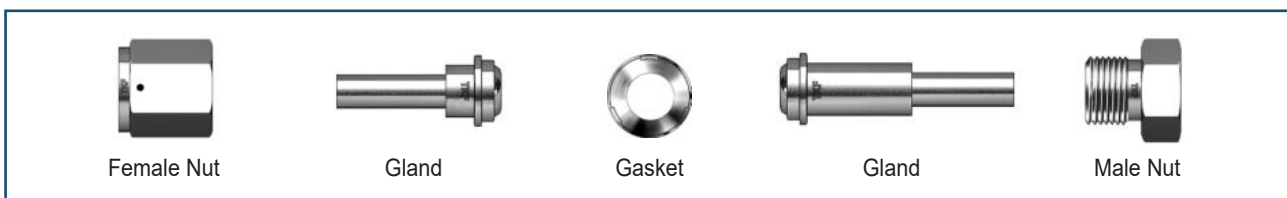

· Dimensions are for reference only and are subject to change.

GLANDS

FEMALE GLAND

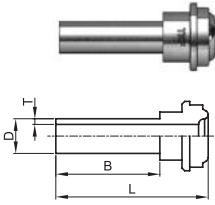

Tube Size	Head Size	Ordering Number	D	T	B	L	ANS (Inch)
1/8"	1/8"	□2SG19	3.18	0.70	19.05	27.40	1/8
1/4"	1/4"	□4SG6	6.35	1.00	6.35	15.24	1/4
1/4"	1/4"	□4SG10	6.35	1.00	10.00	18.89	1/4
1/4"	1/4"	□4SG19	6.35	1.00	19.05	27.94	1/4
3/8"	1/2"	□6SG6	9.53	1.00	6.35	15.75	1/2
3/8"	1/2"	□6SG10	9.53	1.00	10.00	19.40	1/2
3/8"	1/2"	□6SG19	9.53	1.00	19.05	28.45	1/2
1/2"	1/2"	□8SG6	12.70	1.24	6.35	15.75	1/2
1/2"	1/2"	□8SG10	12.70	1.24	10.00	19.40	1/2
1/2"	1/2"	□8SG19	12.70	1.24	19.05	28.45	1/2
3/4"	3/4"	□12SG19	19.05	1.65	19.05	34.50	3/4
1"	1"	□16SG19	25.40	1.65	19.05	38.60	1
1/4"	1/2"	□8 x 4SG6	6.35	1.00	6.35	15.75	1/2
1/4"	1/2"	□8 x 4SG10	6.35	1.00	10.00	19.50	1/2
1/4"	1/2"	□8 x 4SG19	6.35	1.00	19.05	28.45	1/2

ANS : AVAILABLE NUT SIZE

MALE GLAND

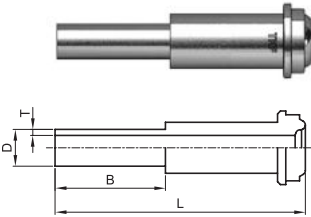

Tube Size	Head Size	Ordering Number	D	T	B	L	ANS (Inch)
1/8"	1/8"	□2LG19	3.18	0.70	19.05	36.00	1/8
1/4"	1/4"	□4LG6	6.35	1.00	6.35	30.48	1/4
1/4"	1/4"	□4LG10	6.35	1.00	10.00	34.13	1/4
1/4"	1/4"	□4LG19	6.35	1.00	19.05	43.18	1/4
3/8"	1/2"	□6LG6	9.53	1.00	6.35	32.77	1/2
3/8"	1/2"	□6LG10	9.53	1.00	10.00	36.42	1/2
3/8"	1/2"	□6LG19	9.53	1.00	19.05	45.47	1/2
1/2"	1/2"	□8LG6	12.70	1.24	6.35	32.77	1/2
1/2"	1/2"	□8LG10	12.70	1.24	10.00	36.42	1/2
1/2"	1/2"	□8LG19	12.70	1.24	19.05	45.47	1/2
3/4"	3/4"	□12LG19	19.05	1.65	19.05	51.56	3/4
1"	1"	□16LG19	25.40	1.65	19.05	58.93	1
1/4"	1/2"	□8 x 4LG6	6.35	1.00	6.35	32.77	1/2
1/4"	1/2"	□8 x 4LG10	6.35	1.00	10.00	36.42	1/2
1/4"	1/2"	□8 x 4LG19	6.35	1.00	19.05	45.47	1/2

ANS : AVAILABLE NUT SIZE

ATW FEMALE LONG GLAND

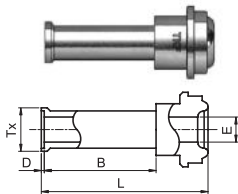

Tube Size	Head Size	Ordering Number	B	D	E	L	Tx
1/4"	1/4"	□4ASG19	19.05	0.5	4.6	28.5	7.4
3/8"	1/2"	□6ASG19	19.05	0.8	7.9	29.2	10.4
1/2"	1/2"	□8ASG19	19.05	1.0	10.2	29.5	14.0
1/4"	1/2"	□8 x 4ASG19	19.05	0.5	10.2	29.5	7.4

ANS : AVAILABLE NUT SIZE

ATW MALE LONG GLAND

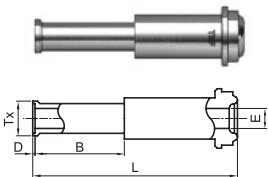

Tube Size	Head Size	Ordering Number	B	D	E	L	Tx
1/4"	1/4"	□4ALG19	19.05	0.5	4.6	43.7	7.4
3/8"	1/2"	□6ALG19	19.05	0.8	7.9	46.2	10.4
1/2"	1/2"	□8ALG19	19.05	1.0	10.2	46.5	14.0
3/4"	3/4"	□12ALG19	19.05	1.0	16.5	52.6	20.3
1"	1"	□16ALG19	24.40	1.0	22.1	65.3	26.9
1/4"	1/2"	□8 x 4ALG19	19.05	0.5	10.2	46.5	7.4

ANS : AVAILABLE NUT SIZE

· Dimensions are for reference only and are subject to change.

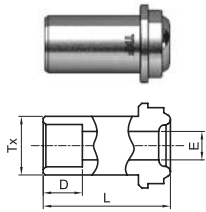

SOCKET WELD SHORT GLAND

Socket Size	Head Size	Ordering Number	D	E	L	Tx
1/4"	1/4"	□4SWSG	7.1	4.6	12.7	8.9

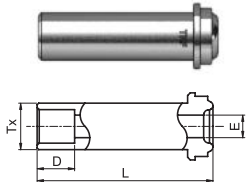

SOCKET WELD LONG GLAND

Socket Size	Head Size	Ordering Number	D	E	L	Tx
1/8"	1/8"	□2SWLG	2.5	2.3	17.8	5.1
1/4"	1/4"	□4SWLG	7.1	4.6	33.3	8.9
3/8"	1/2"	□6SWLG	7.9	7.1	38.1	15.2
1/2"	1/2"	□8SWLG	9.6	10.2	38.1	15.2
3/4"	3/4"	□12SWLG	11.2	15.7	50.8	22.4
1"	1"	□16SWLG	15.7	22.1	56.4	30.2

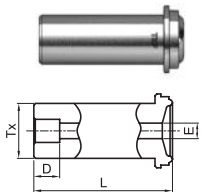

SOCKET WELD REDUCING LONG GLAND

Socket Size	Head Size	Ordering Number	D	E	L	Tx
1/8"	1/4"	□4 x 2SWLG	2.5	2.3	33.3	8.9
1/4"	1/2"	□8 x 4SWLG	7.1	4.6	38.1	15.2

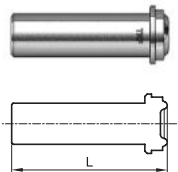

BLIND GLAND

Head Size	Ordering Number	L	Head Size	Ordering Number	L
1/8"	□2BLG	17.8	3/4"	□12BLG	50.8
1/4"	□4BLG	33.3	1"	□16BLG	56.4
1/2"	□8BLG	38.1			

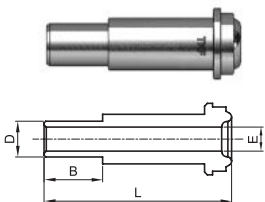

MALE WELD GLAND

Tube Size	Head Size	Ordering Number	D	E	B	L	ANS (Inch)
1/8"	1/8"	□2MG	3.18	1.5	7.1	17.8	1/8
1/4"	1/4"	□4MG	6.35	3.0	10.4	33.3	1/4
3/8"	1/2"	□6MG	9.53	7.1	10.4	38.1	3/8
1/2"	1/2"	□8MG	12.70	10.2	12.7	38.1	1/2

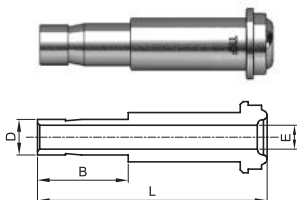

TUBE ADAPTER

Tube Size	Head Size	Ordering Number	D	E	B	L	ANS (Inch)
1/4"	1/4"	□4TA	6.35	4.3	16.2	41	1/4
3/8"	1/2"	□6TA	9.53	6.8	17.8	46	3/8
1/2"	1/2"	□8TA	12.70	9.4	24.4	49.3	1/2

· Dimensions are for reference only and are subject to change.

WELD & METAL SEAL FITTINGS |

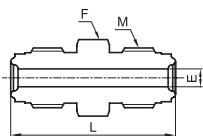

DOUBLE MALE UNION

Head Size	Ordering Number	E	L	F Hex Flat	M
1/8"	□2MU	2.30	28.70	9.52	5/16-24 UNF
1/4"	□4MU	4.35	39.37	15.88	9/16-18 UNF
1/2"	□8MU	10.22	46.74	23.81	7/8-14 UNF
3/4"	□12MU	15.75	61.98	33.34	1 1/4 -18 UNEF
1"	□16MU	22.10	65.79	41.28	1 1/2-20 UN

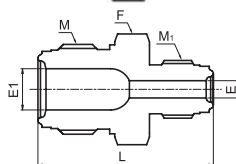

DOUBLE MALE REDUCING UNION

Head Size	Head Size	Ordering Number	E	E ₁	F Hex Flat	L	M	M ₁
1/4"	1/8"	□4 x 2MU	2.30	4.35	15.88	34.8	9/16-18 UNF	5/16-24 UNF
1/2"	1/4"	□8 x 4MU	4.35	10.20	23.81	43.4	7/8-14 UNF	9/16-18 UNF

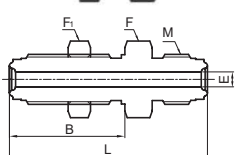

BULKHEAD UNION

Head Size	Ordering Number	E	B	L	F Hex Flat	F ₁ Hex Flat	M
1/4"	□4BH	4.35	33.00	56.60	19.05	19.05	9/16-18 UNF
1/2"	□8BH	10.22	37.60	65.25	26.99	21.99	7/8-14 UNF
3/4"	□12BH	15.75	43.40	79.00	38.1	38.1	1 1/4 -18 UNEF
1"	□16BH	22.10	47.10	86.00	44.45	44.45	1 1/2-20 UN

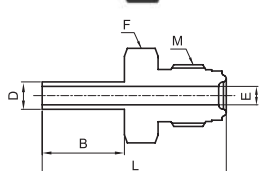

TBW BODY

Tube Size	Ordering Number	D	B	E	L	F Hex Flat	M
1/4"	□4BY19	6.35	19.05	4.35	42.65	15.88	9/16-18 UNF
3/8"	□6BY19	9.53	19.05	10.22	46.70	23.81	7/8-14 UNF
1/2"	□8BY19	12.70	19.05	10.22	46.70	23.81	7/8-14 UNF
3/4"	□12BY19	19.05	19.05	15.75	55.55	33.34	1 1/4 -18 UNEF

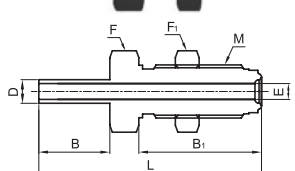

TBW BULKHEAD CONNECTOR

Tube Size	Ordering Number	D	E	B	B ₁	L	F Hex Flat	F ₁ Hex Flat	M
1/4"	□4BHY	6.35	4.35	19.05	33.00	59.85	19.05	15.88	9/16-18 UNF
1/2"	□8BHY	12.70	10.22	19.05	37.60	65.25	26.99	26.99	7/8-14 UNF
3/4"	□12BHY	19.05	15.75	19.05	43.25	71.30	38.1	38.1	1 1/4-18 UNEF

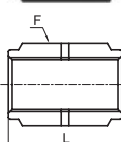
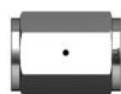

COUPLING

Head Size	Ordering Number	F Hex Flat	L	Head Size	Ordering Number	F Hex Flat	L
1/8"	□2CG	11.11	16.8	3/4"	□12CG	38.1	42.7
1/4"	□4CG	19.05	30.2	1"	□16CG	44.45	51.8
1/2"	□8CG	26.99	33.3				

· Dimensions are for reference only and are subject to change.

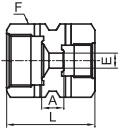

DOUBLE FEMALE REDUCING UNION

Head Size	Head Size	Ordering Number	E	F Hex Flat	A	L
1/2"	1/4"	□8 x 4FU	6.4	26.99	8.9	35.8

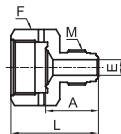

REDUCING ADAPTER

Head Size	Head Size	Ordering Number	E	F Hex Flat	A	L	M
1/8"	1/4"	□2 x 4RA	2.3	19.05	17.5	30.2	5/16-24 UNF
1/4"	1/2"	□4 x 8RA	4.6	26.99	21.6	35.8	9/16-18 UNF

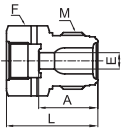

REDUCING BUSHING

Head Size	Head Size	Ordering Number	E	F Hex Flat	A	L	M
1/4"	1/8"	□4 x 2RB	3.3	15.88	19.3	26.9	9/16-18 UNF
1/2"	1/4"	□8 x 4RB	6.4	23.81	23.1	35.8	7/8-14 UNF

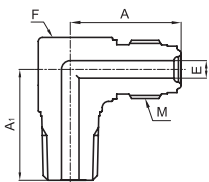

MALE ELBOW (PT)

Head Size	PT SIZE	Ordering Number	E	A	A ₁	F Body Cube	M
1/4"	1/4"	□4ME-X32	4.35	27.18	27.18	17	9/16-18 UNF
1/2"	3/8"	□6ME-X32	10.22	36.83	32.00	25	7/8-14 UNF
1/2"	1/2"	□8ME-X32	10.22	36.83	36.83	25	7/8-14 UNF
3/4"	3/4"	□12ME-X32	15.75	48.80	43.50	33.3	1 1/4-18 UNEF

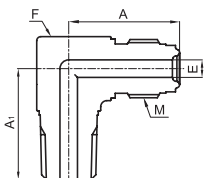

MALE ELBOW (NPT)

Head Size	PT SIZE	Ordering Number	E	A	A ₁	F Body Cube	M
1/4"	1/4"	□4ME	4.35	27.18	27.18	17	9/16-18 UNF
1/2"	3/8"	□6ME	10.22	36.83	32.00	25	7/8-14 UNF
1/2"	1/2"	□8ME	10.22	36.83	36.83	25	7/8-14 UNF
3/4"	3/4"	□12ME	15.75	48.80	43.50	33.3	1 1/4-18 UNEF

· Dimensions are for reference only and are subject to change.

WELD & METAL SEAL FITTINGS |



UNION ELBOW

Head Size	Ordering Number	E	A	F Body Cube	M
1/4"	□4UE	4.35	27.18	17	9/16-18 UNF
1/2"	□8UE	10.22	36.83	25	7/8-14 UNF
3/4"	□12UE	15.75	48.77	33.3	1 1/4-18 UNEF
1"	□16UE	22.10	50.80	42.8	1 1/2-20 UN

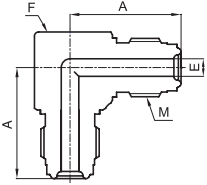

UNION TEE

Head Size	Ordering Number	E	A	L	F Body Cube	M
1/4"	□4UT	4.35	27.18	54.36	17	9/16-18 UNF
1/2"	□8UT	10.22	36.83	73.66	25	7/8-14 UNF
3/4"	□12UT	15.75	48.77	97.54	33.3	1 1/4-18 UNEF
1"	□16UT	22.10	50.80	101.60	42.8	1 1/2-20 UN

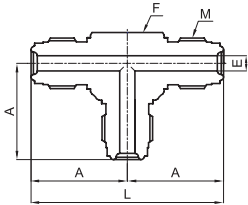

UNION CROSS

Head Size	Ordering Number	E	A	L	F Body Cube	M
1/4"	□4UC	4.35	27.18	54.36	17	9/16-18 UNF
1/2"	□8UC	10.22	36.83	73.66	25	7/8-14 UNF
3/4"	□12UC	15.75	48.77	97.54	33.3	1 1/4-18 UNEF
1"	□16UC	22.10	50.80	101.60	42.8	1 1/2-20 UN

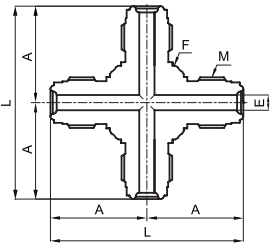

TUBE FITTING CONNECTOR

Tube Size	Head Size	Ordering Number	C	D	E	F Hex Flat	G Hex Flat	H	T	M
1/4"	1/4"	□4MCK	17.80	15.20	4.35	15.88	14.29	41.1	1/4"	9/16-18 UNF
3/8"	1/2"	□6MCK	19.30	16.80	10.22	23.81	17.46	46.7	3/8"	7/8-14 UNF
1/2"	1/2"	□8MCK	21.80	22.90	10.22	23.81	22.23	49.5	1/2"	7/8-14 UNF

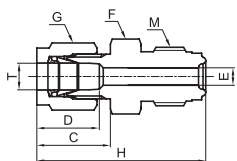

· Dimensions are for reference only and are subject to change.

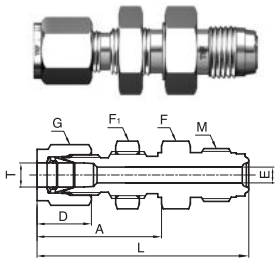

TUBE FITTING BULKHEAD CONNECTOR

Tube Size	Head Size	Ordering Number	A	D	E	F Hex Flat	F ₁ Hex Flat	G Hex Flat	L	T	M
1/4"	1/4"	□4BHCK	33.5	15.20	4.6	15.88	15.88	14.29	57.2	1/4"	9/16-18 UNF
3/8"	1/2"	□6BHCK	36.8	16.80	7.1	23.81	19.05	17.46	64.5	3/8"	7/8-14 UNF
1/2"	1/2"	□8BHCK	41.9	22.90	10.2	23.81	23.81	22.23	69.6	1/2"	7/8-14 UNF

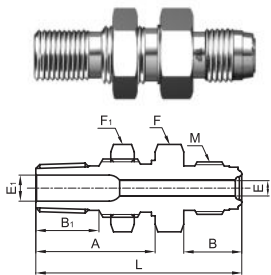

MALE BULKHEAD CONNECTOR (NPT)

Head Size	NPT SIZE	Ordering Number	B	B ₁	E	E ₁	F Hex Flat	F ₁ Hex Flat	A	L	M
1/4"	1/4"	□4BHC	15.7	14.2	4.6	7.1	20.64	20.64	31.5	56.1	9/16-18 UNF
1/2"	1/4"	□8 x 4BHC	19.1	14.2	10.2	7.1	23.81	20.64	31.5	59.4	7/8-14 UNF

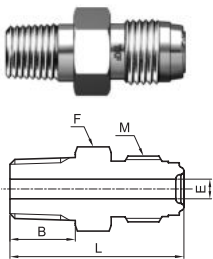

MALE CONNECTOR (PT)

Head Size	PT SIZE	Ordering Number	E	B	L	F Hex Flat	M
1/8"	1/8"	□2MC-X32	2.30	9.60	27.20	11.11	5/16-24 UNF
1/4"	1/4"	□4MC-X32	4.35	14.22	37.84	15.88	9/16-18 UNF
1/2"	3/8"	□6MC-X32	7.44	14.22	41.87	23.81	7/8-14 UNF
1/2"	1/2"	□8MC-X32	10.22	19.05	46.74	23.81	7/8-14 UNF
3/4"	3/4"	□12MC-X32	15.75	19.05	55.63	33.34	1 1/4-18 UNEF
1"	1"	□16MC-X32	22.10	23.88	62.74	41.28	1 1/2-20 UN

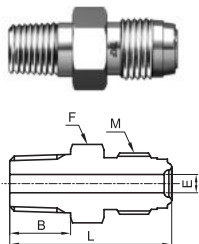

MALE CONNECTOR (NPT)

Head Size	PT SIZE	Ordering Number	E	B	L	F Hex Flat	M
1/8"	1/8"	□2MC	2.30	9.60	27.20	11.11	5/16-24 UNF
1/4"	1/4"	□4MC	4.35	14.22	37.84	15.88	9/16-18 UNF
1/2"	3/8"	□6MC	7.44	14.22	41.87	23.81	7/8-14 UNF
1/2"	1/2"	□8MC	10.22	19.05	46.74	23.81	7/8-14 UNF
3/4"	3/4"	□12MC	15.75	19.05	55.63	33.34	1 1/4-18 UNEF
1"	1"	□16MC	22.10	23.88	62.74	41.28	1 1/2-20 UN

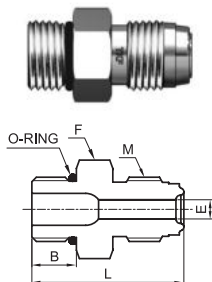

MALE CONNECTOR (ST)

Head Size	ST SIZE	Ordering Number	E	B	L	F Hex Flat	M	UNIFORM O-Ring Size
1/4"	9/16-18 UNF	□4MCS	4.35	9.9	33.8	19.05	9/16-18 UNF	F-906
1/2"	7/8-14 UNF	□8MCS	10.22	12.7	42.2	25.4	7/8-14 UNF	F-910
3/4"	1 3/16-12 UNF	□12MCS	15.75	15.0	51.5	33.34	1 1/16-12 UNF	F-912

· Dimensions are for reference only and are subject to change.

WELD & METAL SEAL FITTINGS |



FEMALE CONNECTOR (PT)

Head Size	PT SIZE	Ordering Number	E	F Hex Flat	L	M
1/8"	1/8"	□2FC-X32	2.30	14.29	30.2	5/16-24 UNF
1/4"	1/4"	□4FC-X32	4.35	19.05	39.1	9/16-18 UNF
1/2"	3/8"	□6FC-X32	7.44	23.81	44.7	7/8-14 UNF
1/2"	1/2"	□8FC-X32	10.22	26.99	50.5	7/8-14 UNF
3/4"	3/4"	□12FC-X32	15.75	33.34	59.9	1 1/4-18 UNEF
1"	1"	□16FC-X32	22.10	41.28	63.8	1 1/2-20 UN

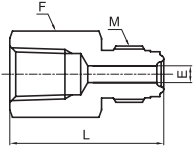

FEMALE CONNECTOR (NPT)

Head Size	NPT SIZE	Ordering Number	E	F Hex Flat	L	M
1/8"	1/8"	□2FC	2.30	14.29	30.2	5/16-24 UNF
1/4"	1/4"	□4FC	4.35	19.05	39.1	9/16-18 UNF
1/2"	3/8"	□6FC	7.44	23.81	44.7	7/8-14 UNF
1/2"	1/2"	□8FC	10.22	26.99	50.5	7/8-14 UNF
3/4"	3/4"	□12FC	15.75	33.34	59.9	1 1/4-18 UNEF
1"	1"	□16FC	22.10	41.28	63.8	1 1/2-20 UN

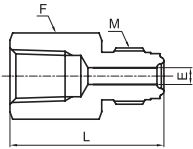

GASKETS

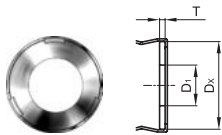

GASKET RETAINER ASSEMBLY

Head Size	Ordering Number	T	D ₁	D _x
1/4"	□4GR	0.8	5.5	11.85
1/2"	□8GR	0.8	11.1	19.27
3/4"	□12GR	0.8	16.8	27.9
1"	□16GR	0.8	22.6	34.2

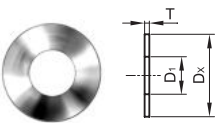

GASKET

Head Size	Ordering Number	T	D ₁	D _x
1/8"	□2GT	0.8	2.3	6.6
1/4"	□4GT	0.8	5.5	12.7
1/2"	□8GT	0.8	11.1	19.8
3/4"	□12GT	0.8	16.8	29
1"	□16GT	0.8	22.6	35.8

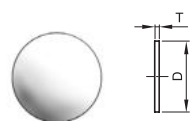

BLIND GASKET

Head Size	Ordering Number	D	T
1/8"	□2GB	6.6	0.8
1/4"	□4GB	11.9	0.8
1/2"	□8GB	19.8	0.8
3/4"	□12GB	28.9	0.8
1"	□16GB	35.5	0.8

· Dimensions are for reference only and are subject to change.

NUTS, CAPS AND PLUGS

FEMALE NUT

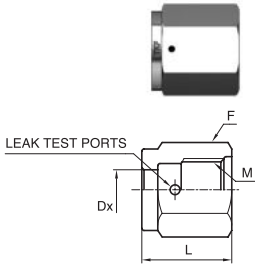

Head Size	Ordering Number	L	F Hex Flat	Dx	M
1/8"	□2FN	13.5	11.11	5.30	5/16-24 UNF
1/4"	□4FN	20.6	19.05	9.10	9/16-18 UNF
1/2"	□8FN	22.4	26.99	15.50	7/8-14 UNF
3/4"	□12FN	28.4	38.10	22.60	1 1/4-18 UNEF
1"	□16FN	34.0	44.45	30.50	1 1/2-20 UN

* Material - S: 316L Stainless Steel SS: 316 Stainless Steel

MALE NUT

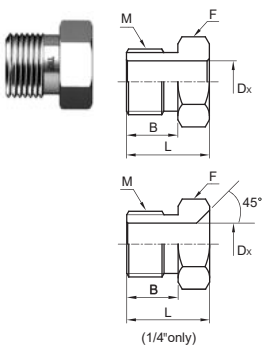

Head Size	Ordering Number	L	B	F Hex Flat	Dx	M
1/8"	□2MN	12.7	8.2	9.52	5.30	5/16-24 UNF
1/4"	□4MN	18.0	11.0	15.88	9.10	9/16-18 UNF
1/4"	□4MNS	13.7	11.0	15.88	9.10	9/16-18 UNF
1/2"	□8MN	20.5	12.7	23.81	15.50	7/8-14 UNF
3/4"	□12MN	25.4	16.0	33.34	22.60	1 1/4-18 UNEF
1"	□16MN	30.2	20.0	41.28	30.50	1 1/2-20 UN

* 4MNS : Short Male Nut 1/4" Only

* Material - S: 316L Stainless Steel SS: 316 Stainless Steel

PLUG

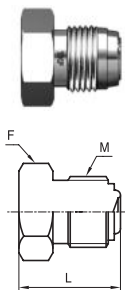

Head Size	Ordering Number	L	F Hex Flat	M
1/8"	□2PG	17.30	9.52	5/16-24 UNF
1/4"	□4PG	23.37	15.88	9/16-18 UNF
1/2"	□8PG	27.43	23.81	7/8-14 UNF
3/4"	□12PG	36.32	33.34	1 1/4 -18 UNEF
1"	□16PG	38.61	41.28	1 1/2-20 UN

CAP

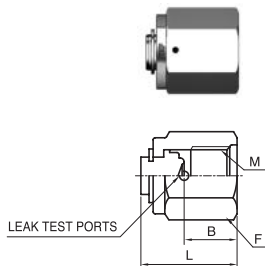

Head Size	Ordering Number	L	B	F Hex Flat	M
1/8"	□2CP	16.00	7.60	11.11	5/16-24 UNF
1/4"	□4CP	24.20	11.18	19.05	9/16-18 UNF
1/2"	□8CP	25.50	11.43	26.99	7/8-14 UNF
3/4"	□12CP	32.77	13.72	38.10	1 1/4-18 UNEF
1"	□16CP	39.12	16.00	44.45	1 1/2-20 UN

· Dimensions are for reference only and are subject to change.

WELD & METAL SEAL FITTINGS |

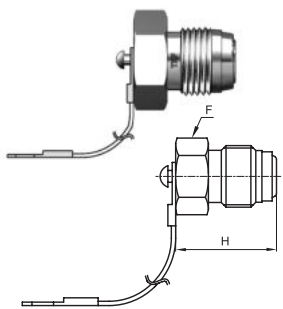

PLUG (CABLE TYPE)

Head Size	Ordering Number	F	H	Cable Length
1/4"	□4PG-C	15.88	23.37	260
1/2"	□8PG-C	23.81	27.43	260

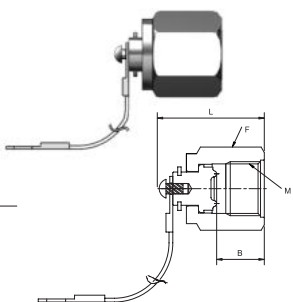

CAP (CABLE TYPE)

Head Size	Ordering Number	L	B	F Hex Flat	M	Cable Length
1/4"	□4CP-C	27.8	11.18	19.05	9/16 - 18 UNF	260
1/2"	□8CP-C	29.0	11.43	26.99	7/8 - 14 UNF	260

HIGH-FLOW CONNECTION - "H" TYPE

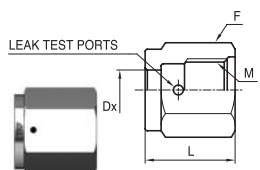

HMFS FEMALE NUT

Head Size	Ordering Number	L	F Hex Flat	Dx	M
1/4"	□4HFN	20.57	19.05	9.90	9/16-18 UNF

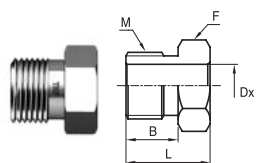

HMFS MALE NUT

Head Size	Ordering Number	B	L	F Hex Flat	Dx	M
1/4"	□4HMN	11.0	18.03	15.88	9.9	9/16-18 UNF

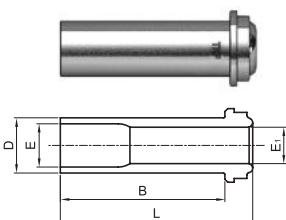

HMFS LONG GLAND

Tube Size	Head Size	Ordering Number	D	B	L	E	E ₁
3/8"	1/4"	□6 x 4HLG	9.53	28.4	33.2	7.5	6.28

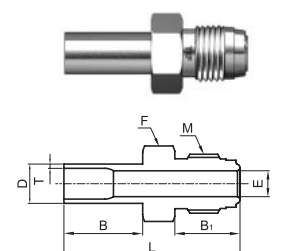

HMFS TBW BODY

Head Size	Tube Size	Ordering Number	D	T	E	B	B ₁	F Hex Flat	L	M
1/4"	3/8"	□4 x 6HBY	9.53	1.00	6.4	19.05	15.7	15.88	42.7	9/16-18 UNF

· Dimensions are for reference only and are subject to change.

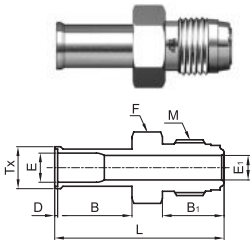

HMFS ATW BODY

Head Size(T)	Tube Size	Ordering Number	B	B ₁	D	E	E ₁	F Hex Flat	L	Tx	M
1/4"	3/8"	□4 x 6HABY	19.05	15.7	0.8	6.4	7.9	15.88	43.4	10.4	9/16-18 UNF

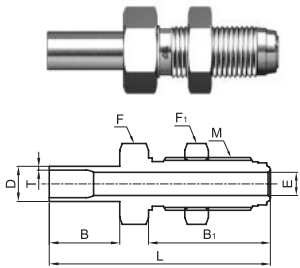

HMFS BULKHEAD CONNECTOR

Head Size	Tube Size	Ordering Number	D	T	B	B ₁	E	F Hex Flat	F ₁ Hex Flat	L	M
1/4"	3/8"	□4 x 6HBHY	9.53	1.00	19.05	33.0	6.4	19.05	19.05	59.9	9/16-18 UNF

WELDED ASSEMBLIES

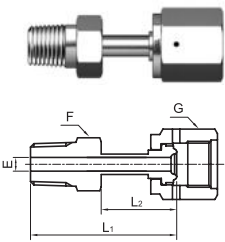

WELDED MALE CONNECTOR (PT)

Head Size	PT SIZE	Ordering Number	E	F Hex Flat	G Hex Flat	L ₁	L ₂
1/4"	1/4"	□4WMC-X32	4.35	14.29	19.05	45.5	23.4
1/2"	3/8"	□6WMC-X32	10.22	17.46	26.99	48.0	25.4
1/2"	1/2"	□8WMC-X32	10.22	22.23	26.99	53.1	25.6

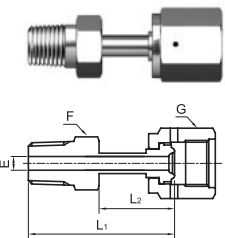

WELDED MALE CONNECTOR (NPT)

Head Size	NPT SIZE	Ordering Number	E	F Hex Flat	G Hex Flat	L ₁	L ₂
1/4"	1/4"	□4WMC	4.35	14.29	19.05	45.5	23.4
1/2"	3/8"	□6WMC	10.22	17.46	26.99	48.0	25.4
1/2"	1/2"	□8WMC	10.22	22.23	26.99	53.1	25.6

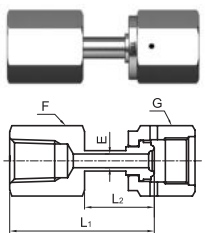

WELDED FEMALE CONNECTOR (PT)

Head Size	PT SIZE	Ordering Number	E	F Hex Flat	G Hex Flat	L ₁	L ₂
1/4"	1/4"	□4FMC-X32	4.35	19.05	19.05	45.0	23.4
1/2"	3/8"	□6FMC-X32	7.44	22.23	26.99	49.5	26.9
1/2"	1/2"	□8FMC-X32	10.22	26.99	26.99	55.4	26.4

· Dimensions are for reference only and are subject to change.

WELD & METAL SEAL FITTINGS |

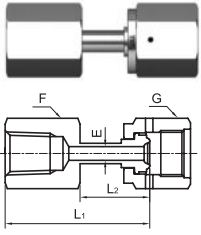

WELDED FEMALE CONNECTOR (NPT)

Head Size	NPT SIZE	Ordering Number	E	F Hex Flat	G Hex Flat	L ₁	L ₂
1/4"	1/4"	□4FMC	4.35	19.05	19.05	45.0	23.4
1/2"	3/8"	□6FMC	7.44	22.23	26.99	49.5	26.9
1/2"	1/2"	□8FMC	10.22	26.99	26.99	55.4	26.4

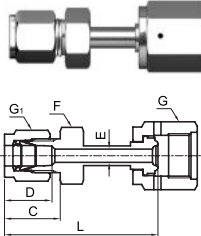

WELDED LOK CONNECTOR

Tube Size	Head Size	Ordering Number	C	D	E	F Hex Flat	G Hex Flat	G ₁ Hex Flat	L
1/4"	1/4"	□4WTC	17.78	15.24	4.35	12.70	19.05	14.29	49.28
3/8"	1/2"	□6WTC	19.30	16.76	10.22	15.88	19.05	17.46	50.04
1/2"	1/2"	□8WTC	21.84	22.86	10.22	20.64	26.99	22.22	56.64

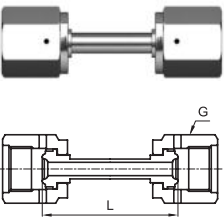

WELDED FEMALE UNION

Head Size	Ordering Number	L	G Hex Flat
1/4"	□4WFU	43.4	19.05
1/2"	□8WFU	46.7	26.99

FEMALE ELBOW UNION WELDED ASSEMBLY

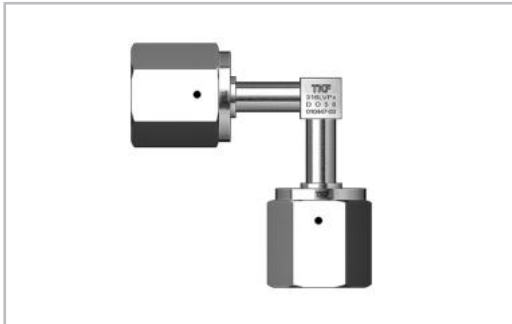

Ordering Number / □ - 4UEW

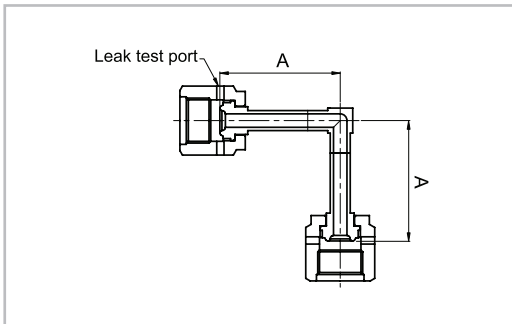

Female Elbow Union Welded Assembly		
Size (OD)	Ordering Number	A
1/4"	□4EUW-X497	25.4
1/4"	□4EUW	38.3

FEMALE TEE UNION WELDED ASSEMBLY

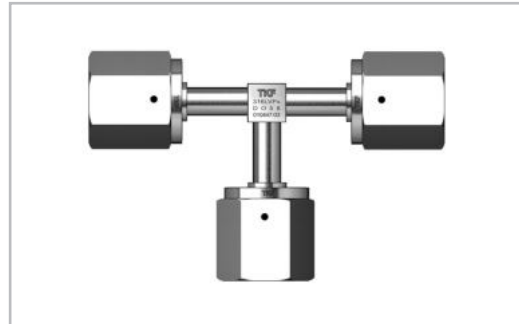

Ordering Number / □ - 4UTW

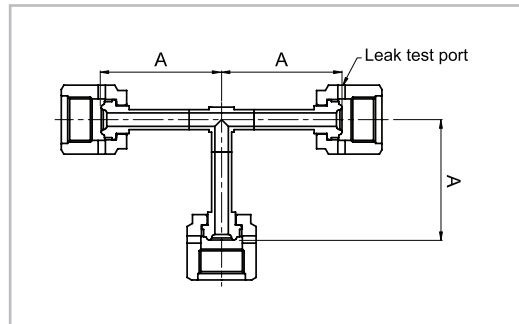

Female Tee Union Welded Assembly		
Size (OD)	Ordering Number	A
1/4"	□4UTW-X497	25.4
1/4"	□4UTW	38.3

· Dimensions are for reference only and are subject to change.