

# CGA Series (Cylinder Connection)

CGA DISS / CGA / DIN / JIS



# CONTENTS

## CGA DISS SERIES

**NIPPLES - 10 Series**

316L Stainless Steel.  
Non-rotating design.  
Heat code traceability.



**NUTS - 20 Series**

303 Stainless Steel Silver Plated.

**GASKETS - 30 Series**

Nickel 200/PCTFE/Aluminum.  
Retainer ring included.

**INLET CONNECTIONS - 40 Series**

Nipple, Nut and Gasket included.

**OUTLET BLANK PLUGS - 50 Series**

316L Stainless Steel.  
Non-rotating design.

**OUTLET ADAPTERS - 70 Series**

316L Stainless Steel.  
Non-rotating design.

**CYLINDER VALVE OUTLET CAPS - 90 Series**

316L Stainless Steel.  
Chain, Ring and Gasket included.  
Gas tight design.

**COMPLETE PIGTAIL CONNECTIONS - 100 Series**

Nipple, Nut, Gasket and Blank Plug included.

## CGA & DIN / JIS SERIES

**NIPPLES - 10 Series**

316L Stainless Steel.

**NUTS - 20 Series**

303 Stainless Steel.



**WASHERS - 30 Series**

Washers available in PCTFE and PTFE.

**INLET CONNECTIONS - 40 Series**

Nipple, Nut and Washer included.

**OUTLET BLANK PLUGS - 50 Series**

316L Stainless Steel.

**OUTLET BLANK CAPS - 60 Series**

316L Stainless Steel.

**OUTLET ADAPTERS - 70 Series**

316L Stainless Steel.

**CYLINDER VALVE OUTLET PLUGS - 80 Series**

303 Stainless Steel.  
Chain and Ring included.

**CYLINDER VALVE OUTLET CAPS - 90 Series**

303 Stainless Steel.  
Chain, Ring and Polyethylene disc included.

**COMPLETE PIGTAIL CONNECTIONS - 100 Series**

Nipple, Nut, Washer and Blank Plug or Cap included.

## GAS CONNECTION ASSIGNMENT TABLE

# TBW AND METAL FACE SEAL FITTINGS

components are ordered by product code as listed in this catalogue

## ORDERING INFORMATION

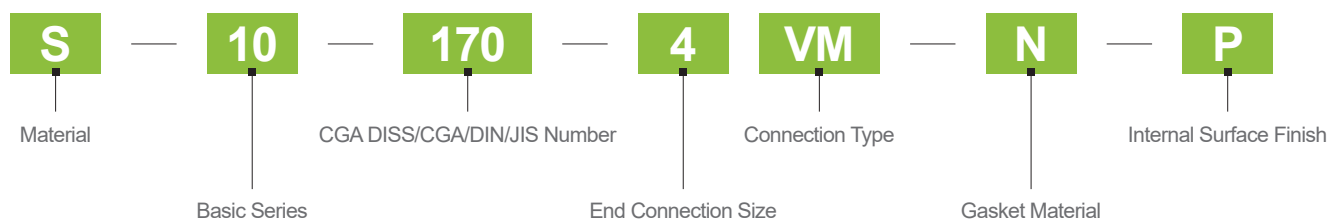

Material	Basic Series	CGA DISS/CGA/DIN/JIS Number
S = 316L Stainless Steel	10 = Nipples	Reference Gas Connection Assignment Table
D = 316L Stainless Steel VAR	20 = Nuts	
3S = 303 Stainless Steel	30 = Gaskets & Washers	
SS = 303 Stainless Steel Silver Plated	40 = Inlet Connection *Nipple, Nut and Gasket *Nipple, Nut and Washer	
N = Nickel 200	50 = Outlet Blank Plugs	
PC = PCTFE	60 = Outlet Blank Caps	
T = PTFE	70 = Outlet Adapters	
AL = Aluminum	80 = Cylinder Valve Outlet Plugs *Chain and Ring included	
	90 = Cylinder Valve Outlet Caps *Chain, Ring and Gasket included *Chain, Ring and Polyethylene disc included	
	100 = Complete Pigtail Connections *Nipple, Nut, Gasket and Blank Plug *Nipple, Nut, Washer and Blank Plug or Cap	

End Connection Size	Connection Type	Gasket Material	Internal Surface Finish (Ry)
2 = 1/8"	TW = Auto Tube Weld	N = Nickel 200	BLANK = 3.0µm
4 = 1/4"	VM = MFS Male	PC = PCTFE	P = 0.7µm
	NM = NPT Male	T = PTFE	
	NF = NPT Female	AL = Aluminum	
		PD = Polyethylene disc	

# CGA DISS Series

NIPPLES - 10 Series

NUTS - 20 Series

GASKETS - 30 Series

INLET CONNECTIONS - 40 Series

OUTLET BLANK PLUGS - 50 Series

OUTLET ADAPTERS - 70 Series

CYLINDER VALVE OUTLET CAPS - 90 Series

COMPLETE PIGTAIL CONNECTIONS - 100 Series



# CGA DISS SERIES

## INLET CONNECTIONS (NIPPLE, NUT AND GASKET INCLUDED)

AUTO TUBE WELD

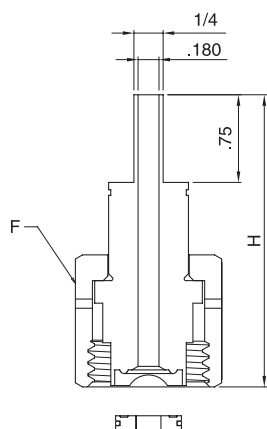

FACESEAL MALE

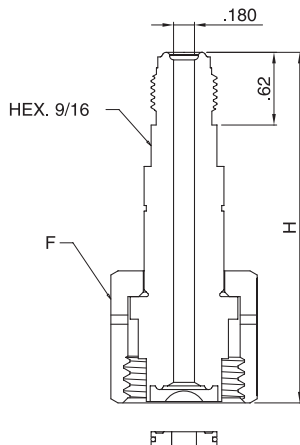

NPT MALE

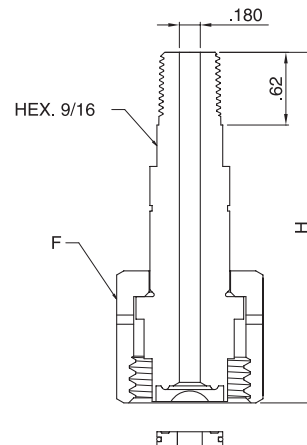

CGA DISS Number	End Connection	Assembly Part Number	H Overall Length		Nipple Part Number	Nut Part Number	F Hex Flat	Gasket Part Number (Nickel)	Gasket Part Number (PCTFE)	Gasket Part Number (Aluminum)
			in	mm						
632	1/4" Auto Tube Weld	□-40-632-4TW-□□	2.50	63.5	□-10-632-4TW-□	SS-20-630	1-1/4	N-30-630	PC-30-630	AL-30-630
	1/4" Face Seal Male	□-40-632-4VM-□□	3.00	76.2	□-10-632-4VM-□					
	1/4" NPT Male	□-40-632-4NM-□□	3.00	76.2	□-10-632-4NM-□					
634	1/4" Auto Tube Weld	□-40-634-4TW-□□	2.50	63.5	□-10-634-4TW-□	SS-20-630	1-1/4	N-30-630	PC-30-630	AL-30-630
	1/4" Face Seal Male	□-40-634-4VM-□□	3.00	76.2	□-10-634-4VM-□					
	1/4" NPT Male	□-40-634-4NM-□□	3.00	76.2	□-10-634-4NM-□					
636	1/4" Auto Tube Weld	□-40-636-4TW-□□	2.50	63.5	□-10-636-4TW-□	SS-20-630	1-1/4	N-30-630	PC-30-630	AL-30-630
	1/4" Face Seal Male	□-40-636-4VM-□□	3.00	76.2	□-10-636-4VM-□					
	1/4" NPT Male	□-40-636-4NM-□□	3.00	76.2	□-10-636-4NM-□					
638	1/4" Auto Tube Weld	□-40-638-4TW-□□	2.50	63.5	□-10-638-4TW-□	SS-20-630	1-1/4	N-30-630	PC-30-630	AL-30-630
	1/4" Face Seal Male	□-40-638-4VM-□□	3.00	76.2	□-10-638-4VM-□					
	1/4" NPT Male	□-40-638-4NM-□□	3.00	76.2	□-10-638-4NM-□					
640	1/4" Auto Tube Weld	□-40-640-4TW-□□	2.50	63.5	□-10-640-4TW-□	SS-20-630	1-1/4	N-30-630	PC-30-630	AL-30-630
	1/4" Face Seal Male	□-40-640-4VM-□□	3.00	76.2	□-10-640-4VM-□					
	1/4" NPT Male	□-40-640-4NM-□□	3.00	76.2	□-10-640-4NM-□					
642	1/4" Auto Tube Weld	□-40-642-4TW-□□	2.50	63.5	□-10-642-4TW-□	SS-20-630	1-1/4	N-30-630	PC-30-630	AL-30-630
	1/4" Face Seal Male	□-40-642-4VM-□□	3.00	76.2	□-10-642-4VM-□					
	1/4" NPT Male	□-40-642-4NM-□□	3.00	76.2	□-10-642-4NM-□					
712	1/4" Auto Tube Weld	□-40-712-4TW-□□	2.50	63.5	□-10-712-4TW-□	SS-20-710	1-3/8	N-30-630	PC-30-630	AL-30-630
	1/4" Face Seal Male	□-40-712-4VM-□□	3.00	76.2	□-10-712-4VM-□					
	1/4" NPT Male	□-40-712-4NM-□□	3.00	76.2	□-10-712-4NM-□					
714	1/4" Auto Tube Weld	□-40-714-4TW-□□	2.50	63.5	□-10-714-4TW-□	SS-20-710	1-3/8	N-30-630	PC-30-630	AL-30-630
	1/4" Face Seal Male	□-40-714-4VM-□□	3.00	76.2	□-10-714-4VM-□					
	1/4" NPT Male	□-40-714-4NM-□□	3.00	76.2	□-10-714-4NM-□					
716	1/4" Auto Tube Weld	□-40-716-4TW-□□	2.50	63.5	□-10-716-4TW-□	SS-20-710	1-3/8	N-30-630	PC-30-630	AL-30-630
	1/4" Face Seal Male	□-40-716-4VM-□□	3.00	76.2	□-10-716-4VM-□					
	1/4" NPT Male	□-40-716-4NM-□□	3.00	76.2	□-10-716-4NM-□					

# CGA DISS SERIES

## INLET CONNECTIONS (NIPPLE, NUT AND GASKET INCLUDED) CONTINUED FROM PREVIOUS PAGE

CGA DISS Number	End Connection	Assembly Part Number	H Overall Length		Nipple Part Number	Nut Part Number	F Hex Flat	Gasket Part Number (Nickel)	Gasket Part Number (PCTFE)	Gasket Part Number (Aluminum)
			in	mm						
718	1/4" Auto Tube Weld	□-40-718-4TW-□-□	2.50	63.5	□-10-718-4TW-□	SS-20-710	1-3/8	N-30-630	PC-30-630	AL-30-630
	1/4" Faceseal Male	□-40-718-4VM-□-□	3.00	76.2	□-10-718-4VM-□					
	1/4" NPT Male	□-40-718-4NM-□-□	3.00	76.2	□-10-718-4NM-□					
720	1/4" Auto Tube Weld	□-40-720-4TW-□-□	2.50	63.5	□-10-720-4TW-□	SS-20-710	1-3/8	N-30-630	PC-30-630	AL-30-630
	1/4" Faceseal Male	□-40-720-4VM-□-□	3.00	76.2	□-10-720-4VM-□					
	1/4" NPT Male	□-40-720-4NM-□-□	3.00	76.2	□-10-720-4NM-□					
722	1/4" Auto Tube Weld	□-40-722-4TW-□-□	2.50	63.5	□-10-722-4TW-□	SS-20-710	1-3/8	N-30-630	PC-30-630	AL-30-630
	1/4" Faceseal Male	□-40-722-4VM-□-□	3.00	76.2	□-10-722-4VM-□					
	1/4" NPT Male	□-40-722-4NM-□-□	3.00	76.2	□-10-722-4NM-□					
724	1/4" Auto Tube Weld	□-40-724-4TW-□-□	2.50	63.5	□-10-724-4TW-□	SS-20-710	1-3/8	N-30-630	PC-30-630	AL-30-630
	1/4" Faceseal Male	□-40-724-4VM-□-□	3.00	76.2	□-10-724-4VM-□					
	1/4" NPT Male	□-40-724-4NM-□-□	3.00	76.2	□-10-724-4NM-□					
726	1/4" Auto Tube Weld	□-40-726-4TW-□-□	2.50	63.5	□-10-726-4TW-□	SS-20-710	1-3/8	N-30-630	PC-30-630	AL-30-630
	1/4" Faceseal Male	□-40-726-4VM-□-□	3.00	76.2	□-10-726-4VM-□					
	1/4" NPT Male	□-40-726-4NM-□-□	3.00	76.2	□-10-726-4NM-□					
728	1/4" Auto Tube Weld	□-40-728-4TW-□-□	2.50	63.5	□-10-728-4TW-□	SS-20-710	1-3/8	N-30-630	PC-30-630	AL-30-630
	1/4" Faceseal Male	□-40-728-4VM-□-□	3.00	76.2	□-10-728-4VM-□					
	1/4" NPT Male	□-40-728-4NM-□-□	3.00	76.2	□-10-728-4NM-□					

CGA SERIES

UHP PRODUCTS / FITTING SERIES

## GASKETS (CGA DISS 632~728)

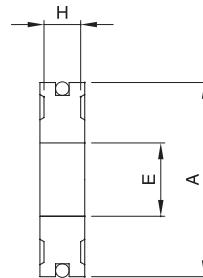

Gasket Part Number	Material	A		E		H	
		in	mm	in	mm	in	mm
N-30-630	Nickel 200	.563	14.3	.213	5.4	.105	2.7
PC-30-630	PCTFE	.563	14.3	.213	5.4	.125	3.2
AL-30-630	Aluminum	.563	14.3	.213	5.4	.105	2.7



# CGA DISS SERIES

## OUTLET ADAPTERS AND BLANK PLUGS

BLANK PLUG

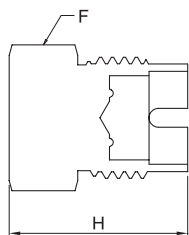

FACESEAL MALE

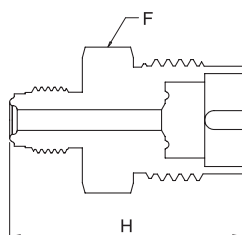

NPT FEMALE

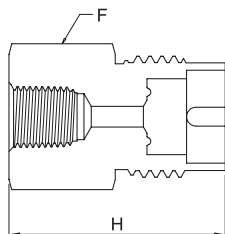

CGA DISS Number	End Connection	Part Number	H Overall Length		F Hex Flat
			in	mm	
632	Blank Plug 1/4" Faceseal Male 1/4" NPT Female	□-50-632-□	1.53	38.9	1-1/8
		□-70-632-4VM-□	2.00	50.8	
		□-70-632-4NF-□	1.85	47.0	
634	Blank Plug 1/4" Faceseal Male 1/4" NPT Female	□-50-632-□	1.53	38.9	1-1/8
		□-70-634-4VM-□	2.00	50.8	
		□-70-634-4NF-□	1.85	47.0	
636	Blank Plug 1/4" Faceseal Male 1/4" NPT Female	□-50-632-□	1.53	38.9	1-1/8
		□-70-636-4VM-□	2.00	50.8	
		□-70-636-4NF-□	1.85	47.0	
638	Blank Plug 1/4" Faceseal Male 1/4" NPT Female	□-50-632-□	1.53	38.9	1-1/8
		□-70-638-4VM-□	2.00	50.8	
		□-70-638-4NF-□	1.85	47.0	
640	Blank Plug 1/4" Faceseal Male 1/4" NPT Female	□-50-632-□	1.53	38.9	1-1/8
		□-70-640-4VM-□	2.00	50.8	
		□-70-640-4NF-□	1.85	47.0	
642	Blank Plug 1/4" Faceseal Male 1/4" NPT Female	□-50-632-□	1.53	38.9	1-1/8
		□-70-642-4VM-□	2.00	50.8	
		□-70-642-4NF-□	1.85	47.0	
712	Blank Plug 1/4" Faceseal Male 1/4" NPT Female	□-50-712-□	1.53	38.9	1-1/4
		□-70-712-4VM-□	2.00	50.8	
		□-70-712-4NF-□	1.85	47.0	
714	Blank Plug 1/4" Faceseal Male 1/4" NPT Female	□-50-712-□	1.53	38.9	1-1/4
		□-70-714-4VM-□	2.00	50.8	
		□-70-714-4NF-□	1.85	47.0	
716	Blank Plug 1/4" Faceseal Male 1/4" NPT Female	□-50-712-□	1.53	38.9	1-1/4
		□-70-716-4VM-□	2.00	50.8	
		□-70-716-4NF-□	1.85	47.0	
718	Blank Plug 1/4" Faceseal Male 1/4" NPT Female	□-50-712-□	1.53	38.9	1-1/4
		□-70-718-4VM-□	2.00	50.8	
		□-70-718-4NF-□	1.85	47.0	
720	Blank Plug 1/4" Faceseal Male 1/4" NPT Female	□-50-720-□	1.53	38.9	1-1/4
		□-70-720-4VM-□	2.00	50.8	
		□-70-720-4NF-□	1.85	47.0	
722	Blank Plug 1/4" Faceseal Male 1/4" NPT Female	□-50-720-□	1.53	38.9	1-1/4
		□-70-722-4VM-□	2.00	50.8	
		□-70-722-4NF-□	1.85	47.0	
724	Blank Plug 1/4" Faceseal Male 1/4" NPT Female	□-50-720-□	1.53	38.9	1-1/4
		□-70-724-4VM-□	2.00	50.8	
		□-70-724-4NF-□	1.85	47.0	
726	Blank Plug 1/4" Faceseal Male 1/4" NPT Female	□-50-720-□	1.53	38.9	1-1/4
		□-70-726-4VM-□	2.00	50.8	
		□-70-726-4NF-□	1.85	47.0	
728	Blank Plug 1/4" Faceseal Male 1/4" NPT Female	□-50-720-□	1.53	38.9	1-1/4
		□-70-728-4VM-□	2.00	50.8	
		□-70-728-4NF-□	1.85	47.0	

CGA SERIES

UHP PRODUCTS / FITTING SERIES

# CGA DISS SERIES

## CYLINDER VALVE OUTLET CAPS (CHAIN, RING AND GASKET INCLUDED)

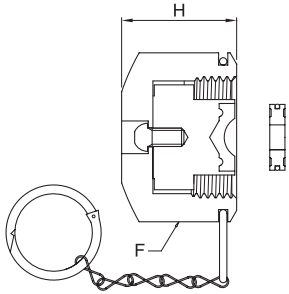

CGA DISS Number	Assembly Part Number	H Overall Length		F Hex Flat	Gasket Part Number (Nickel)	Gasket Part Number (PCTFE)	Gasket Part Number (Aluminum)
		in	mm				
632	□-90-630-□-□	.98	24.9	1-1/4	N-30-630	PC-30-630	AL-30-630
634	□-90-630-□-□	.98	24.9	1-1/4	N-30-630	PC-30-630	AL-30-630
636	□-90-630-□-□	.98	24.9	1-1/4	N-30-630	PC-30-630	AL-30-630
638	□-90-630-□-□	.98	24.9	1-1/4	N-30-630	PC-30-630	AL-30-630
640	□-90-630-□-□	.98	24.9	1-1/4	N-30-630	PC-30-630	AL-30-630
642	□-90-630-□-□	.98	24.9	1-1/4	N-30-630	PC-30-630	AL-30-630
712	□-90-710-□-□	.98	24.9	1-3/8	N-30-630	PC-30-630	AL-30-630
714	□-90-710-□-□	.98	24.9	1-3/8	N-30-630	PC-30-630	AL-30-630
716	□-90-710-□-□	.98	24.9	1-3/8	N-30-630	PC-30-630	AL-30-630
718	□-90-710-□-□	.98	24.9	1-3/8	N-30-630	PC-30-630	AL-30-630
720	□-90-710-□-□	.98	24.9	1-3/8	N-30-630	PC-30-630	AL-30-630
722	□-90-710-□-□	.98	24.9	1-3/8	N-30-630	PC-30-630	AL-30-630
724	□-90-710-□-□	.98	24.9	1-3/8	N-30-630	PC-30-630	AL-30-630
726	□-90-710-□-□	.98	24.9	1-3/8	N-30-630	PC-30-630	AL-30-630
728	□-90-710-□-□	.98	24.9	1-3/8	N-30-630	PC-30-630	AL-30-630

## COMPLETE PIGTAIL CONNECTIONS (NIPPLE, NUT, GASKET AND BLANK PLUG INCLUDED)

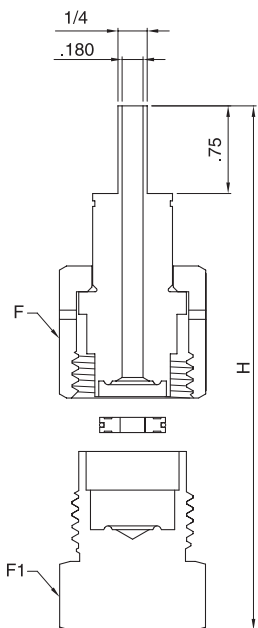

CGA DISS Number	Assembly Part Number	H Overall Length		F Hex Flat	F <sub>1</sub> Hex Flat	Gasket Part Number (Nickel)	Gasket Part Number (PCTFE)	Gasket Part Number (Aluminum)
		in	mm					
632	□-100-632-4TW-□-□	3.4	86.4	1-1/4	1-1/8	N-30-630	PC-30-630	AL-30-630
634	□-100-634-4TW-□-□	3.4	86.4	1-1/4	1-1/8	N-30-630	PC-30-630	AL-30-630
636	□-100-636-4TW-□-□	3.4	86.4	1-1/4	1-1/8	N-30-630	PC-30-630	AL-30-630
638	□-100-638-4TW-□-□	3.4	86.4	1-1/4	1-1/8	N-30-630	PC-30-630	AL-30-630
640	□-100-640-4TW-□-□	3.4	86.4	1-1/4	1-1/8	N-30-630	PC-30-630	AL-30-630
642	□-100-642-4TW-□-□	3.4	86.4	1-1/4	1-1/8	N-30-630	PC-30-630	AL-30-630
712	□-100-712-4TW-□-□	3.4	86.4	1-3/8	1-1/4	N-30-630	PC-30-630	AL-30-630
714	□-100-714-4TW-□-□	3.4	86.4	1-3/8	1-1/4	N-30-630	PC-30-630	AL-30-630
716	□-100-716-4TW-□-□	3.4	86.4	1-3/8	1-1/4	N-30-630	PC-30-630	AL-30-630
718	□-100-718-4TW-□-□	3.4	86.4	1-3/8	1-1/4	N-30-630	PC-30-630	AL-30-630
720	□-100-720-4TW-□-□	3.4	86.4	1-3/8	1-1/4	N-30-630	PC-30-630	AL-30-630
722	□-100-722-4TW-□-□	3.4	86.4	1-3/8	1-1/4	N-30-630	PC-30-630	AL-30-630
724	□-100-724-4TW-□-□	3.4	86.4	1-3/8	1-1/4	N-30-630	PC-30-630	AL-30-630
726	□-100-726-4TW-□-□	3.4	86.4	1-3/8	1-1/4	N-30-630	PC-30-630	AL-30-630
728	□-100-728-4TW-□-□	3.4	86.4	1-3/8	1-1/4	N-30-630	PC-30-630	AL-30-630



# CGA & DIN/JIS Series

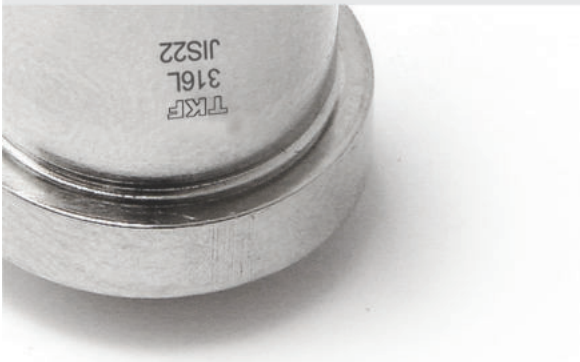

## CGA SERIES

NIPPLES - 10 Series

NUTS - 20 Series

WASHERS - 30 Series

INLET CONNECTIONS - 40 Series

OUTLET BLANK PLUGS - 50 Series

OUTLET BLANK CAPS - 60 Series

OUTLET ADAPTERS - 70 Series

CYLINDER VALVE OUTLET PLUGS - 80 Series

CYLINDER VALVE OUTLET CAPS - 90 Series

COMPLETE PIGTAIL CONNECTIONS - 100 Series



## DIN / JIS SERIES

COMPLETE PIGTAIL CONNECTIONS - 100 Series



# CGA SERIES

## INLET CONNECTIONS (NIPPLE, NUT AND WASHER INCLUDED)

AUTO TUBE WELD

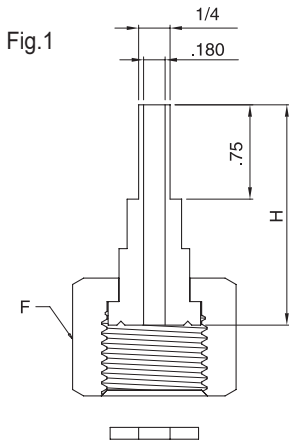

FACESEAL MALE

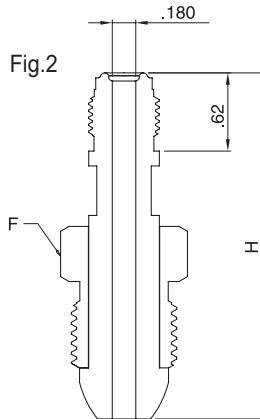

NPT MALE

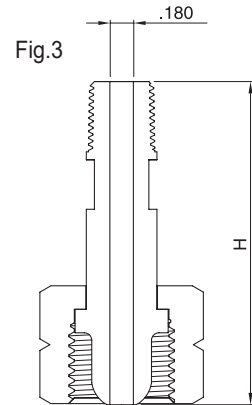

CGA DISS Number	Ref. DWG Inlet Connection	End Connection	Assembly Part Number	H Overall Length	Nipple Part Number	Nut Part Number	F Hex Flat	Washer Part Number (PCTFE)	Washer Part Number (PTFE)
170	Fig. 1	1/4" Auto Tube Weld 1/8" NPT Male	□-40-170-4TW-T-□ □-40-170-2NM-T-□	1-1/4 1-1/4	□-10-170-4TW-□ □-10-170-2NM-□	3S-20-170	3S-20-170	-	T-30-170
180	Fig. 1	1/4" Auto Tube Weld 1/8" NPT Male	□-40-180-4TW-T-□ □-40-180-2NM-T-□	1-1/4 1-3/4	□-10-180-4TW-□ □-10-180-2NM-□	3S-20-180	3S-20-180	-	T-30-180
290	Fig. 3	1/4" Auto Tube Weld 1/4" NPT Male	□-40-290-4TW-□ □-40-290-4NM-□	2-5/8 2-1/4	□-10-290-4TW-□ □-10-290-4NM-□	3S-20-290	3S-20-290	-	-
296	Fig. 2	1/4" Auto Tube Weld 1/4" Face Seal Male 1/4" NPT Male	□-40-296-4TW-□ □-40-296-4VM-□ □-40-296-4NM-□	2-5/8 2-3/4 3-1/2	□-10-296-4TW-□ □-10-296-4VM-□ □-10-296-4NM-□	3S-20-296	3S-20-296	-	-
320	Fig. 1	1/4" Auto Tube Weld 1/4" Face Seal Male 1/4" NPT Male	□-40-320-4TW-□-□ □-40-320-4VM-□-□ □-40-320-4NM-□-□	1-3/4 2-3/4 3-1/2	□-10-320-4TW-□ □-10-320-4VM-□ □-10-320-4NM-□	3S-20-320	3S-20-320	PC-30-320	T-30-320
326	Fig. 3	1/4" Auto Tube Weld 1/4" Face Seal Male 1/4" NPT Male	□-40-326-4TW-□ □-40-326-4VM-□ □-40-326-4NM-□	2-1/4 2-1/4 3	□-10-326-4TW-□ □-10-326-4VM-□ □-10-326-4NM-□	3S-20-326	3S-20-326	-	-
330	Fig. 1	1/4" Auto Tube Weld 1/4" Face Seal Male 1/4" NPT Male	□-40-330-4TW-□-□ □-40-330-4VM-□-□ □-40-330-4NM-□-□	1-3/4 1-3/4 2-1/2	□-10-330-4TW-□ □-10-330-4VM-□ □-10-330-4NM-□	3S-20-330	3S-20-330	PC-30-330	T-30-330
346	Fig. 3	1/4" Auto Tube Weld 1/4" Face Seal Male 1/4" NPT Male	□-40-346-4TW-□ □-40-346-4VM-□ □-40-346-4NM-□	2-5/16 2-1/4 3	□-10-346-4TW-□ □-10-346-4VM-□ □-10-346-4NM-□	3S-20-346	3S-20-346	-	-
350	Fig. 3	1/4" Auto Tube Weld 1/4" Face Seal Male 1/4" NPT Male	□-40-350-4TW-□ □-40-350-4VM-□ □-40-350-4NM-□	2-5/16 2-1/4 3	□-10-350-4TW-□ □-10-350-4VM-□ □-10-350-4NM-□	3S-20-350	3S-20-350	-	-

# CGA SERIES

## INLET CONNECTIONS (NIPPLE, NUT AND WASHER INCLUDED) CONTINUED FROM PREVIOUS PAGE

CGA DISS Number	Ref. DWG Inlet Connection	End Connection	Assembly Part Number	H Overall Length	Nipple Part Number	Nut Part Number	F Hex Flat	Washer Part Number (PCTFE)	Washer Part Number (PTFE)
510	Fig. 2	1/4" Auto Tube Weld	□-40-510-4TW-□	2-5/8	□-10-510-4TW-□	3S-20-510	1-1/8	-	-
		1/4" Faceseal Male	□-40-510-4VM-□	2-3/4	□-10-510-4VM-□				
		1/4" NPT Male	□-40-510-4NM-□	3-1/2	□-10-510-4NM-□				
540	Fig. 3	1/4" Auto Tube Weld	□-40-540-4TW-□	2-1/4	□-10-540-4TW-□	3S-20-540	1-1/8	-	-
		1/4" Faceseal Male	□-40-540-4VM-□	2-1/4	□-10-540-4VM-□				
		1/4" NPT Male	□-40-540-4NM-□	3	□-10-540-4NM-□				
580	Fig. 2	1/4" Auto Tube Weld	□-40-580-4TW-□	2-5/8	□-10-580-4TW-□	3S-20-580	1-1/8	-	-
		1/4" Faceseal Male	□-40-580-4VM-□	2-3/4	□-10-580-4VM-□				
		1/4" NPT Male	□-40-580-4NM-□	3-1/2	□-10-580-4NM-□				
590	Fig. 2	1/4" Auto Tube Weld	□-40-590-4TW-□	2-1/2	□-10-590-4TW-□	3S-20-590	1-1/8	-	-
		1/4" Faceseal Male	□-40-590-4VM-□	2-3/4	□-10-590-4VM-□				
		1/4" NPT Male	□-40-590-4NM-□	3-1/2	□-10-590-4NM-□				
660	Fig. 1	1/4" Auto Tube Weld	□-40-660-4TW-□-□	2-3/16	□-10-660-4TW-□	3S-20-660	1-1/4	PC-30-660	T-30-660
		1/4" Faceseal Male	□-40-660-4VM-□-□	1-7/8	□-10-660-4VM-□				
		1/4" NPT Male	□-40-660-4NM-□-□	2-1/2	□-10-660-4NM-□				
670	Fig. 1	1/4" Auto Tube Weld	□-40-670-4TW-□-□	2-3/16	□-10-670-4TW-□	3S-20-670	1-1/4	PC-30-670	T-30-670
		1/4" Faceseal Male	□-40-670-4VM-□-□	1-7/8	□-10-670-4VM-□				
		1/4" NPT Male	□-40-670-4NM-□-□	2-1/2	□-10-670-4NM-□				
678	Fig. 1	1/4" Auto Tube Weld	□-40-678-4TW-□-□	2-1/2	□-10-678-4TW-□	3S-20-678	1-1/4	PC-30-678	T-30-678
		1/4" Faceseal Male	□-40-678-4VM-□-□	2	□-10-678-4VM-□				
		1/4" NPT Male	□-40-678-4NM-□-□	2-1/2	□-10-678-4NM-□				
679	Fig. 1	1/4" Auto Tube Weld	□-40-679-4TW-□-□	2-1/2	□-10-679-4TW-□	3S-20-679	1-1/4	PC-30-679	T-30-679
		1/4" Faceseal Male	□-40-679-4VM-□-□	2	□-10-679-4VM-□				
		1/4" NPT Male	□-40-679-4NM-□-□	3	□-10-679-4NM-□				

# CGA SERIES

## OUTLET ADAPTERS AND BLANK PLUGS OR CAPS

BLANK PLUG

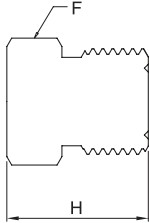

BLANK CAP

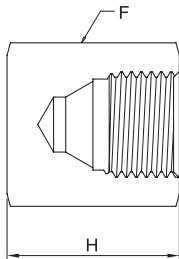

FACESEAL MALE

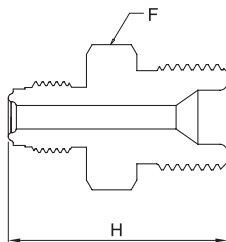

NPT FEMALE

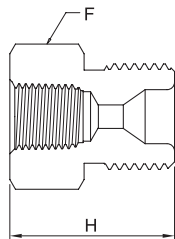

CGA DISS Number	End Connection	Part Number	H Overall Length		F Hex Flat
			in	mm	
296	Blank Cap	□-60-296-□	1.37	34.8	1-1/8
	1/4" Face Seal Male	□-70-296-4VM-□	2.00	50.8	
	1/4" NPT Female	□-70-296-4NF-□	2.00	50.8	
320	Blank Plug	□-50-320-□	1.12	28.4	1
	1/4" Face Seal Male	□-70-320-4VM-□	1.74	44.2	
	1/4" NPT Female	□-70-320-4NF-□	1.12	28.4	
326	Blank Plug	□-50-326-□	1.12	28.4	1
	1/4" Face Seal Male	□-70-326-4VM-□	1.74	44.2	
	1/4" NPT Female	□-70-326-4NF-□	1.31	33.3	
330	Blank Plug	□-50-330-□	1.12	28.4	1
	1/4" Face Seal Male	□-70-330-4VM-□	1.74	44.2	
	1/4" NPT Female	□-70-330-4NF-□	1.31	33.3	
346	Blank Plug	□-50-346-□	1.12	28.4	1
	1/4" Face Seal Male	□-70-346-4VM-□	1.88	47.8	
	1/4" NPT Female	□-70-346-4NF-□	1.31	33.3	
350	Blank Plug	□-50-350-□	1.12	28.4	1
	1/4" Face Seal Male	□-70-350-4VM-□	1.88	47.8	
	1/4" NPT Female	□-70-350-4NF-□	1.31	33.3	
510	Blank Cap	□-60-510-□	1.37	34.8	1-1/4
	1/4" Face Seal Male	□-70-510-4VM-□	2.00	50.8	
	1/4" NPT Female	□-70-510-4NF-□	2.00	50.8	
540	Blank Plug	□-50-540-□	1.12	28.4	1
	1/4" Face Seal Male	□-70-540-4VM-□	1.87	47.5	
	1/4" NPT Female	□-70-540-4NF-□	1.25	31.8	
580	Blank Cap	□-60-580-□	1.37	34.8	1-1/4
	1/4" Face Seal Male	□-70-580-4VM-□	2.00	50.8	
	1/4" NPT Female	□-70-580-4NF-□	2.00	50.8	
590	Blank Cap	□-60-590-□	1.37	34.8	1-1/4
	1/4" Face Seal Male	□-70-590-4VM-□	2.00	50.8	
	1/4" NPT Female	□-70-590-4NF-□	2.00	50.8	
660	Blank Plug	□-50-660-□	0.88	22.4	1-1/8
	1/4" Face Seal Male	□-70-660-4VM-□	1.50	38.1	
	1/4" NPT Female	□-70-660-4NF-□	1.25	31.8	
670	Blank Plug	□-50-670-□	0.88	22.4	1-1/8
	1/4" Face Seal Male	□-70-670-4VM-□	1.50	38.1	
	1/4" NPT Female	□-70-670-4NF-□	1.25	31.8	
678	Blank Plug	□-50-678-□	1.00	25.4	1-1/8
	1/4" Face Seal Male	□-70-678-4VM-□	1.50	38.1	
	1/4" NPT Female	□-70-678-4NF-□	1.38	35.1	
679	Blank Plug	□-50-679-□	0.88	22.4	1-1/8
	1/4" Face Seal Male	□-70-679-4VM-□	1.75	44.5	
	1/4" NPT Female	□-70-679-4NF-□	1.25	31.8	

# CGA SERIES

## CYLINDER VALVE OUTLET PLUGS OR CAPS (CHAIN, RING AND POLYETHYLENE DISC INCLUDED)

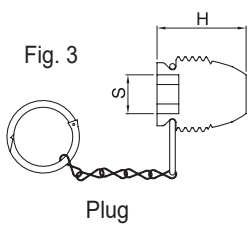
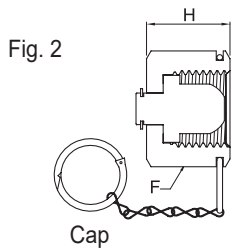
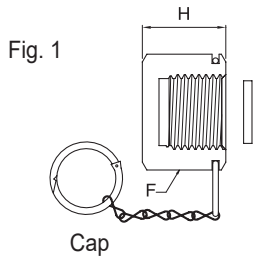

CGA Number	Ref. DWG	Assembly Part Number	H Overall Length		F Hex Flat	S Hex Flat	Washer Material
			in	mm			
320	Fig. 1	□-90-320-PD-□	.54	13.7	1	-	Polyethylene disc
326	Fig. 1	□-90-326-PD-□	.54	13.7	1	-	Polyethylene disc
330	Fig. 1	□-90-330-PD-□	.54	13.7	1	-	Polyethylene disc
346	Fig. 1	□-90-346-PD-□	.54	13.7	1	-	Polyethylene disc
350	Fig. 2	□-90-350-□	.82	20.8	1-1/8	-	-
510	Fig. 3	□-80-510-□	1	25.4	-	3/8	-
580	Fig. 3	□-80-580-□	1	25.4	-	3/8	-
590	Fig. 3	□-80-590-□	1	25.4	-	3/8	-
660	Fig. 1	□-90-660-PD-□	.54	13.7	1-1/4	-	Polyethylene disc
670	Fig. 1	□-90-670-PD-□	.54	13.7	1-1/4	-	Polyethylene disc
678	Fig. 1	□-90-678-PD-□	.54	13.7	1-1/4	-	Polyethylene disc
679	Fig. 1	□-90-679-PD-□	.54	13.7	1-1/4	-	Polyethylene disc

## COMPLETE PIGTAIL CONNECTIONS (NIPPLE, NUT, WASHER AND BLANK PLUG OR CAP INCLUDED)

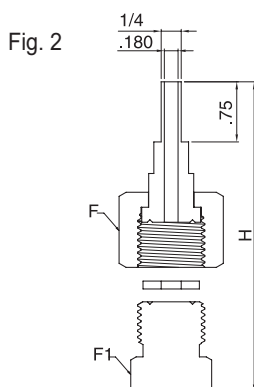
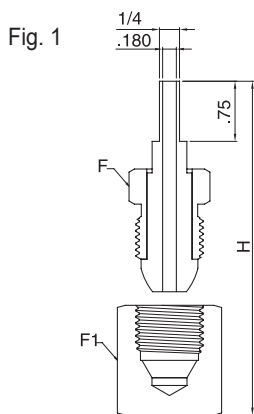

CGA Number	Ref. DWG	Assembly Part Number	H Overall Length		F Hex Flat	F1 Hex Flat	Washer Part Number (PTFE)	Washer Part Number (PTFE)	Seal Enhancers Part Number (Nickel)
			in	mm					
296	Fig. 1	□-100-296-4TW-□	3.03	77	7/8	1-1/8	-	-	-
320	Fig. 2	□-100-320-4TW-□□	2.96	75.2	1-1/8	1	PC-30-320	T-30-320	-
326	Fig. 1	□-100-326-4TW-□	3.01	76.5	1-1/8	1	-	-	-
330	Fig. 2	□-100-330-4TW-□□	2.96	75.2	1-1/8	1	PC-30-330	T-30-330	-
346	Fig. 1	□-100-346-4TW-□	2.97	75.4	1-1/8	1	-	-	-
350	Fig. 1	□-100-350-4TW-□	2.96	75.2	1-1/8	1	-	-	-
510	Fig. 1	□-100-510-4TW-□	3.03	77	1-1/8	1-1/4	-	-	-
540	Fig. 1	□-100-540-4TW-□	2.96	75.2	1-1/8	1	-	-	-
580	Fig. 1	□-100-580-4TW-□	3.03	77	1-1/8	1-1/4	-	-	-
590	Fig. 1	□-100-590-4TW-□	3.03	77	1-1/8	1-1/4	-	-	-
660	Fig. 2	□-100-660-4TW-□□	2.96	75.2	1-1/4	1-1/8	PC-30-660	T-30-660	-
670	Fig. 2	□-100-670-4TW-□□	2.96	75.2	1-1/4	1-1/8	PC-30-670	T-30-670	-
678	Fig. 2	□-100-678-4TW-□□	3.08	78.2	1-1/4	1-1/8	PC-30-678	T-30-678	-
679	Fig. 2	□-100-679-4TW-□□	2.96	75.2	1-1/4	1-1/8	PC-30-679	T-30-679	-

# DIN SERIES

## COMPLETE PIGTAIL CONNECTIONS (NIPPLE, NUT, WASHER AND BLANK PLUG INCLUDED)

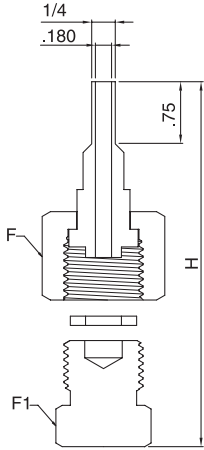

CGA Number	Assembly Part Number	H Overall Length		F Hex Flat	F <sub>1</sub> Hex Flat	Washer Part Number (PTFE)
		in	mm			
1	□-100-DIN1-4TW-T-□	2.96	75.2	1-1/4	1-1/4	T-30-DIN1
5	□-100-DIN5-4TW-T-□	3.09	78.5	1-1/4	1-1/4	T-30-DIN5
6	□-100-DIN6-4TW-T-□	2.96	75.2	1-1/4	1-1/4	T-30-DIN6
8	□-100-DIN8-4TW-T-□	3.09	78.5	1-1/4	1-1/4	T-30-DIN8
11	□-100-DIN11-4TW-T-□	2.88	73.2	7/8	11/16	T-30-DIN11
14	□-100-DIN14-4TW-T-□	2.88	73.2	1-1/16	7/8	T-30-DIN14

CGA SERIES

# JIS SERIES

## COMPLETE PIGTAIL CONNECTIONS (NIPPLE, NUT, WASHER AND BLANK PLUG INCLUDED)

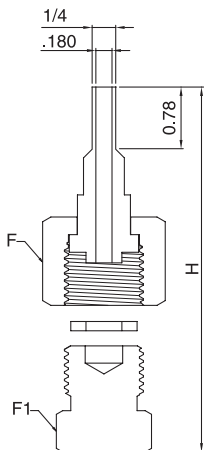

JIS Number	Assembly Part Number	H Overall Length		F Hex Flat	F <sub>1</sub> Hex Flat	Washer Part Number (PCTFE)
		in	mm			
22R	□-100-JIS22R-4TW-PC-□	3.25	82.6	1-1/4	1-1/4	PC-30-JIS22
22L	□-100-JIS22L-4TW-PC-□	3.25	82.6	1-1/4	1-1/4	PC-30-JIS22
26R	□-100-JIS26R-4TW-PC-□	3.14	79.8	1-1/4	1-1/4	PC-30-JIS26
26L	□-100-JIS26L-4TW-PC-□	3.14	79.8	1-1/4	1-1/4	PC-30-JIS26

UHP PRODUCTS / FITTING SERIES



# GAS CONNECTION ASSIGNMENT TABLE

GAS	CGA DISS	CGA	DIN	JIS
Ammonia	720	705	DIN 6	22-R
Argon	718	580	DIN 6	22-R or 23-R
Arsenic Pentafluoride	642	-	-	-
Arsine	632	350	-	22-L
Boron Trichloride	634	660	DIN 8	-
Boron Trifluoride	642	330	DIN 8	22-L
Carbon Dioxide	716	320	DIN 6	-
Carbon Monoxide	724	350	DIN 5	22-L
Chlorine	728	-	DIN 8	26-R
Diborane	632	350	-	22-L
Dichlorosilane	636	678	DIN 5	-
Diethylzinc	726	510	-	-
Diethyltelluride	726	-	-	-
Dimethylzinc	726	-	-	-
Disilane	632	-	-	-
Germane	632	350 or 660	-	-
Halocarbon 11	716	660	-	-
Halocarbon 12	716	660	DIN 6	-
Halocarbon 13	716	660	DIN 6	-
Halocarbon 14	716	320 or 580	DIN 6	-
Halocarbon 23	716	660	DIN 6	-
Halocarbon 115	716	660	DIN 6	-
Halocarbon 116	716	660	-	-
Helium	718	580	DIN 6	22-R or 23-R
Hydrogen	724	350	DIN 1	22-L
Hydrogen Bromide	634	330	DIN 8	26-R
Hydrogen Chloride	634	330	DIN 8	26-R
Hydrogen Fluoride	638	660 or 670	-	26-R
Hydrogen Sulfide	722	330	DIN 5	-
Krypton	718	580	DIN 6	22-R or 23-R
Neon	718	580	DIN 6	22-R or 23-R
Nitrogen	718	580	DIN 10	22-R or 23-R
Nitrogen Trifluoride	640	330 or 670	DIN 8	-
Nitrous Oxide	712	326	DIN 8	-
Oxygen	714	540	DIN 9	22-R or 23-R
Perfluoropropane	716	660	-	-
Phosphine	632	350 or 660	DIN 1	-
Phosphorus Pentafluoride	642	330 or 660	-	-
Silane	632	350	-	-
Silicon Tetrachloride	636	-	-	-
Silicon Tetrafluoride	642	330	-	22-L
Sulphur Hexafluoride	716	590	DIN 6	26-R
Trichlorosilane	636	-	-	-
Triethylaluminum	726	510	-	-
Tungsten Hexafluoride	638	670	DIN 8	-
Xenon	718	580	DIN 6	22-R

## \* Gas Connection Assignment Table Sources

- Compressed Gas Association Publication V-1 (2005 Edition)
- Deutscher Institute für Normung 477 Part 1 (May 1990 Edition)
- Japanese Industrial Standard B8244 (Translated) (1989 Edition)
- Japanese Industrial Standard B8246 (Translated) (1989 Edition)
- International Organization for Standardization ISO/DIS 407 (1983 Edition)
- Deutscher Institute für Normung 477 Part 8 (1990 Edition)