

Plug Valves



PV SERIES

- Maximum Working Pressure : 3,000 psig (206bar) @ 100°F (37°C)
- Working Temperature Range : -10°F (-23°C) to 400°F (204°C)

ORDERING INFORMATION

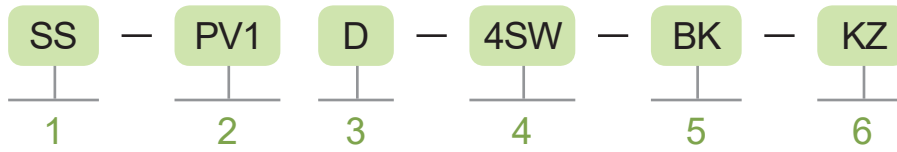

1. BODY MATERIAL

Material	Designator
316 SS	SS

2. VALVE SERIES

Orifice Size	Designator
2.3mm, 4.4mm	PV1
7.1mm	PV2

* The Orifice Size is determined using valves with TKF tube fitting end connections.
 * For more details, See the Dimensions Table.

3. VENT PORT OPTION

Vent Port Option	Designator
Without	Blank
Downstream Vent	D

4. INLET/OUTLET CONNECTION SIZE & TYPE

Inlet/Outlet Connection Size	Designator
1/8"	2
1/4"	4
3/8"	6
1/2"	8
6mm	6M
8mm	8M
10mm	10M
12mm	12M

Inlet/Outlet Connection Type	Designator
Lok	SW
Male NPT	NM
Female NPT	NF
Male ISO® Tapered	PTM
Female ISO® Tapered	PTF

① Refer to specifications ISO 7/1, BS EN 10226-1, DIN-2999, and JIS B0203.

5. HANDLE TYPE

Handle Type	Designator
Dark green Plastic Handle (Standard)	Blank
Black Plastic Handle	BK
Blue Plastic Handle	BL
Red Plastic Handle	RD
Locking Handle	L
Metal Handle (stainless steel)	S
Metal Handle (aluminum)	A

6. SEAL MATERIAL

Seal Material	Designator
PTFE-coated fluorocarbon FKM (Standard)	Blank
PTFE-coated Buna N	PBN
PTFE-coated ethylene propylene	PEP
PTFE-coated neoprene	PNE
Kalrez®	KZ

FEATURES

- Straight pattern
- Simple and Compact design
- Replacable plug assembly and O-ring

TECHNICAL DATA

TEMPERATURE - WORKING PRESSURE RATING

- Based on PTFE-coated fluorocarbon FKM O-rings.

Series	PV1 / PV2
Material	316 SS
Temperature, °F (°C)	Working Pressure, psig (bar)
-10 (-23) to 100 (37)	3,000 (206)
150 (65)	3,000 (206)
250 (121)	2,000 (137)
300 (148)	1,000 (68.9)
350 (176)	1,000 (68.9)
400 (204)	1,000 (68.9)

OPERATION

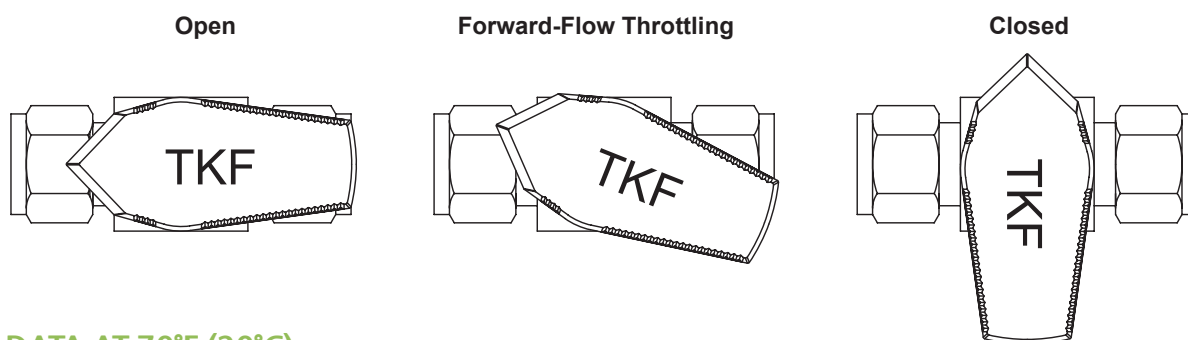

FLOW DATA AT 70°F (20°C)

End Connections		Cv	Series	Pressure Drop to Atmosphere, psi (bar)					
				1 (0.068)			5 (0.34)		
Inlet/Outlet	Size			Air Flow, std ft ³ /min (std L/min)			Water Flow, U.S. gal/min (L/min)		
Fractional TKF tube fittings	1/8"	0.1	PV1	0.3 (8.4)	0.8 (22)	1.1 (31)	0.1 (0.37)	0.2 (0.75)	0.3 (1.1)
	1/4"	1.6	PV1	6.0 (160)	13 (360)	18 (500)	1.6 (6.0)	3.6 (13)	5.1 (19)
	3/8"	1.1	PV1	4.1 (110)	8.9 (250)	12 (330)	1.1 (4.1)	2.5 (9.4)	3.5 (13)
		4.4	PV2	23 (650)	52 (1,470)	72 (2,030)	6.4 (24)	14 (52)	20 (75)
Metric TKF tube fittings	1/2"	4.4	PV2	16 (450)	35 (990)	49 (1,380)	4.4 (16)	9.8 (37)	13 (49)
	6mm	1.6	PV1	6.0 (160)	13 (360)	18 (500)	1.6 (6.0)	3.6 (13)	5.1 (19)
	8mm	4.4	PV2	23 (650)	52 (1,470)	72 (2030)	6.4 (24)	14 (52)	20 (75)
	10mm								
Female NPT	12mm	4.8	PV2	17 (480)	39 (1,100)	54 (1,520)	4.8 (18)	10 (37)	15 (56)
	1/8"	1.2	PV1	4.4 (120)	9.7 (270)	13 (360)	1.2 (4.5)	2.7 (10)	3.8 (14)
		0.9	PV1	3.3 (93)	7.3 (200)	10 (280)	0.9 (3.4)	2.0 (7.5)	2.8 (10)
	1/4"		4.3	PV2	16 (450)	34 (960)	48 (1,350)	4.3 (16)	9.6 (36)
Male NPT		1/2"	2.7	PV2	10 (280)	21 (590)	30 (840)	2.7 (10)	6.0 (22)
	1/8"	1	PV1	3.7 (100)	8.1 (220)	11 (310)	1.0 (3.7)	2.2 (8.3)	3.2 (12)
				1/4"					
Male NPT/ Swagelok tube fitting	1/2"	2.4	PV2	9.0 (250)	19 (530)	27 (760)	2.4 (9.0)	5.4 (20)	7.6 (28)
	1/4"	0.9	PV1	3.3 (93)	7.3 (200)	10 (280)	0.9 (3.4)	2.0 (7.5)	2.8 (10)
		1	PV1	3.7 (100)	8.1 (220)	11 (310)	1.0 (3.7)	2.2 (8.3)	3.2 (12)
Male/Female NPT	1/4"	0.9	PV1	3.3 (93)	7.3 (200)	10 (280)	0.9 (3.4)	2.0 (7.5)	2.8 (10)
Female ISO® Tapered	1/2"	2.7	PV2	10 (280)	21 (590)	30 (840)	2.7 (10)	6.0 (22)	8.5 (32)

① Refer to specifications ISO 7/1, BS EN 10226-1, DIN-2999, and JIS B0203.

PLUG VALVES |

TESTING

- Every valve is factory tested for shutoff at 600 psig (41.3 bar)

CLEANING AND PACKAGING

- Every valve is cleaned and packaged in accordance with the standard specification of cleaning and packaging.

MATERIALS OF CONSTRUCTION

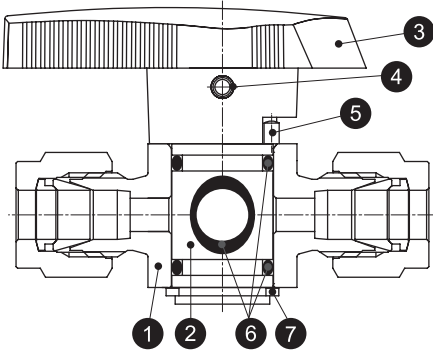

No.	Description	Material
		Material Grade/ASTM Specification
1	Body	316 SS / A479
2	Plug	PTFE-coated 316 SS / A479
3	Handle	Polythermide
4	Pin	304 SS
5	Stop Pin	316 SS
6	O-Ring	PTFE-coated fluorocarbon FKM
7	Snap Ring	304 SS

DIMENSIONS

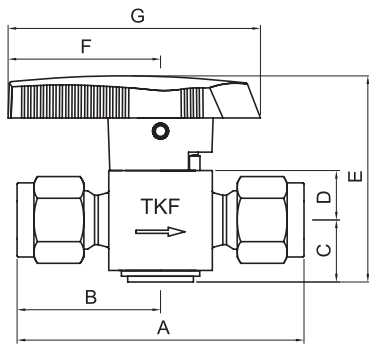

PV1 SERIES

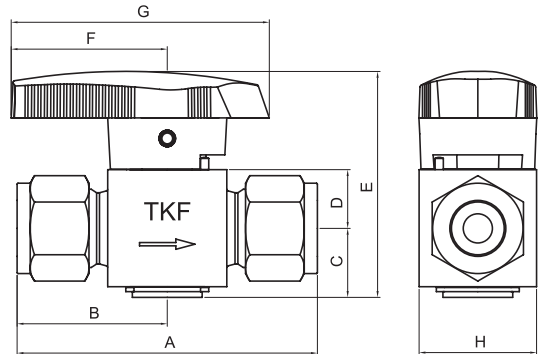

PV2 SERIES

Series	Ordering Number Part No.	Orifice in. (mm)	Cv	End Connections		Dimensions in. (mm)							
				Inlet	Outlet	A	B	C	D	E	F	G	H
PV1	2SW	0.091 (2.3)	0.1	1/8" Lok	1.99 (50.5)	0.995 (25.25)	0.46 (11.8)	0.37 (9.4)	1.54 (39.2)	1.14 (29.0)	1.89 (48.0)	0.75 (19.05)	
	4SW		1.6	1/4" Lok	2.17 (55.1)	1.085 (27.55)							
	6SW		1.1	3/8" Lok	2.29 (58.2)	1.145 (29.1)							
	6MSW		1.6	6mm Lok	2.17 (55.1)	1.085 (27.55)							
	2NF	0.173 (4.4)	1.2	1/8" Female NPT	1.78 (45.2)	0.89 (22.6)							
	4NF		0.9	1/4" Female NPT	2.09 (53.1)	1.045 (26.55)							
	2NM		1.0	1/8" Male NPT	1.53 (38.9)	0.765 (19.45)							
	4NM			1/4" Male NPT	1.90 (48.3)	0.95 (24.15)							
	4PTF		0.9	1/4" Female ISO® Tapered	2.21 (56.1)	1.105 (28.05)							
	PV2		6SW	0.280 (7.1)	6.4	3/8" Lok							2.66 (67.6)
8SW		4.4	1/2" Lok		2.88 (73.2)	1.44 (36.6)							
8MSW		6.4	8mm Lok		2.66 (67.6)	1.33 (33.8)							
10MSW			10mm Lok		2.68 (68.1)	1.34 (34.05)							
12MSW		4.8	12mm Lok		2.96 (75.2)	1.48 (37.6)							
4NF		4.3	1/4" Female NPT		2.38 (60.5)	1.19 (30.25)							
8NF		2.7	1/2" Female NPT		2.88 (73.2)	1.44 (36.6)							
8NM		2.4	1/2" Male NPT		2.64 (67.1)	1.32 (33.55)							
8PTF		2.7	1/2" Female ISO® Tapered		3.14 (79.8)	1.57 (39.9)							

① Refer to specifications ISO 7/1, BS EN 10226-1, DIN-2999, and JIS B0203.