

LOW PRESSURE MANUAL DIAPHRAGM VALVE

STD TYPE

FEATURES

- Reduced inner capacity
- Electropolished, D.I. water cleaned, assembled, tested and packaged in a certified clean room
- Minimal contributions of Moisture, Oxygen and Hydrocarbon
- Permanently heat code laser marked; material traceable to original mill certificate of test
- Hastelloy® C-22™ and custom configurations available upon request



MAJOR SPECIFICATIONS

Size	1/4"	3/8", 1/2"	3/4"
Cv Value	0.3	0.7	0.7
Orifice Size	4.5mm	7mm	7mm
Max. Working Pressure (G.)	1MPa		
Max. Working Temp.	PCTFE : -10°C ~ 80°C / PI, PFA : -10°C ~ 150°C		
Internal Leakage Allowance (He)	1x10 ⁻¹⁰ Pa · m ³ /s		
Test Pressure ≤ 1×10⁻² Torr			
Holding Time ≥ 30 sec.			
External Leakage Allowance (He)	1x10 ⁻¹⁰ Pa · m ³ /s		
Test Pressure ≤ 1×10⁻² Torr			
Holding Time ≥ 1 min.			
Particle Inspection (EP only)	No count		
Pressure : 60~80psi N₂ Gas			
Sample Volume : 1CFM			
0.1µm and Larger			

PRODUCT GRADE

GRADE	AP	BA	EP
Inner Surface Roughness	Ry ≤ 25µm Cut off Length : 2.5mm Measuring Length : 12.5mm	Ry ≤ 3.0µm 10 µinch Ra(Avg.) Cut off Length : 0.8mm Measuring Length : 4mm	Ry ≤ 0.7µm 5 µinch Ra(Avg.) Cut off Length : 0.25mm Measuring Length : 1.25mm
Polishing	Machining Finish	Machining Finish	Electro Polishing Finish

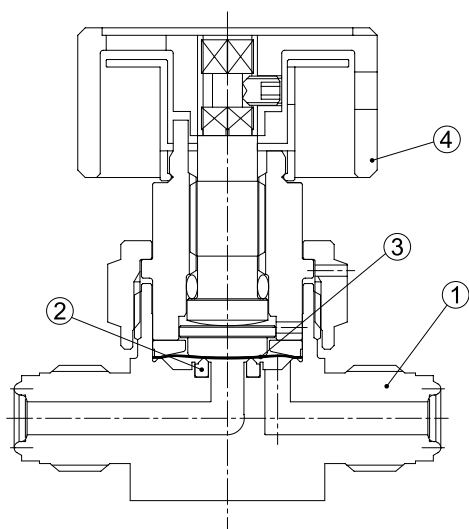

MATERIAL

NO.	NAME	MATERIAL
1	Body	316L Stainless Steel 316L Stainless Steel VAR 304 Stainless Steel
2	Seat	PCTFE / PI / PFA
3	Diaphragm	Ni-Co Alloy
4	Handle	Aluminum

ORDERING INFORMATION

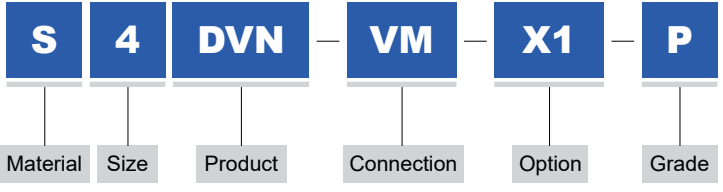

MATERIAL		SIZE		CONNECTION		OPTION		GRADE	
S	316L Stainless Steel	4	1/4"	VM	MFS Male	×47	Constant Bleed ø0.3	AP	AP Grade
D	316L Stainless Steel VAR	6	3/8"	VF	MFS Female	×59	Constant Bleed ø0.6	BLANK	BA Grade
4S	304 Stainless Steel	8	1/2"	SW	Lok			P	EP Grade
		12	3/4"	TW	Butt Weld				

MODEL	CONNECTION	SIZE	A	B	C	D	F	G	H
	MFS Male	1/4"	57	11	64.3	40	26	25.4	
		3/8"	76.2	16	76.8	40	37	28	
		1/2"	76.2	16	76.8	40	37	28	
		3/4"	122	22	82.8	40	37	28	
	MFS Female	1/4"	70.6	11	64.3	40	26	25.4	
		3/8"	83	16	76.8	40	37	28	
		1/2"	83	16	76.8	40	37	28	
		3/4"	122	22	82.8	40	37	28	
	Lok	1/4"	69.5	11	64.3	40	26	25.4	55
		3/8"	82.5	16	76.8	40	37	28	68
		1/2"	91	16	76.8	40	37	28	70
		3/4"	106	22	82.8	40	37	28	84
	Butt Weld	1/4"	54	11	64.3	40	26	25.4	
		3/8"	69	16	76.8	40	37	28	
		1/2"	69	16	76.8	40	37	28	
		3/4"	150	22	82.8	40	37	28	